

# Technical Documentation

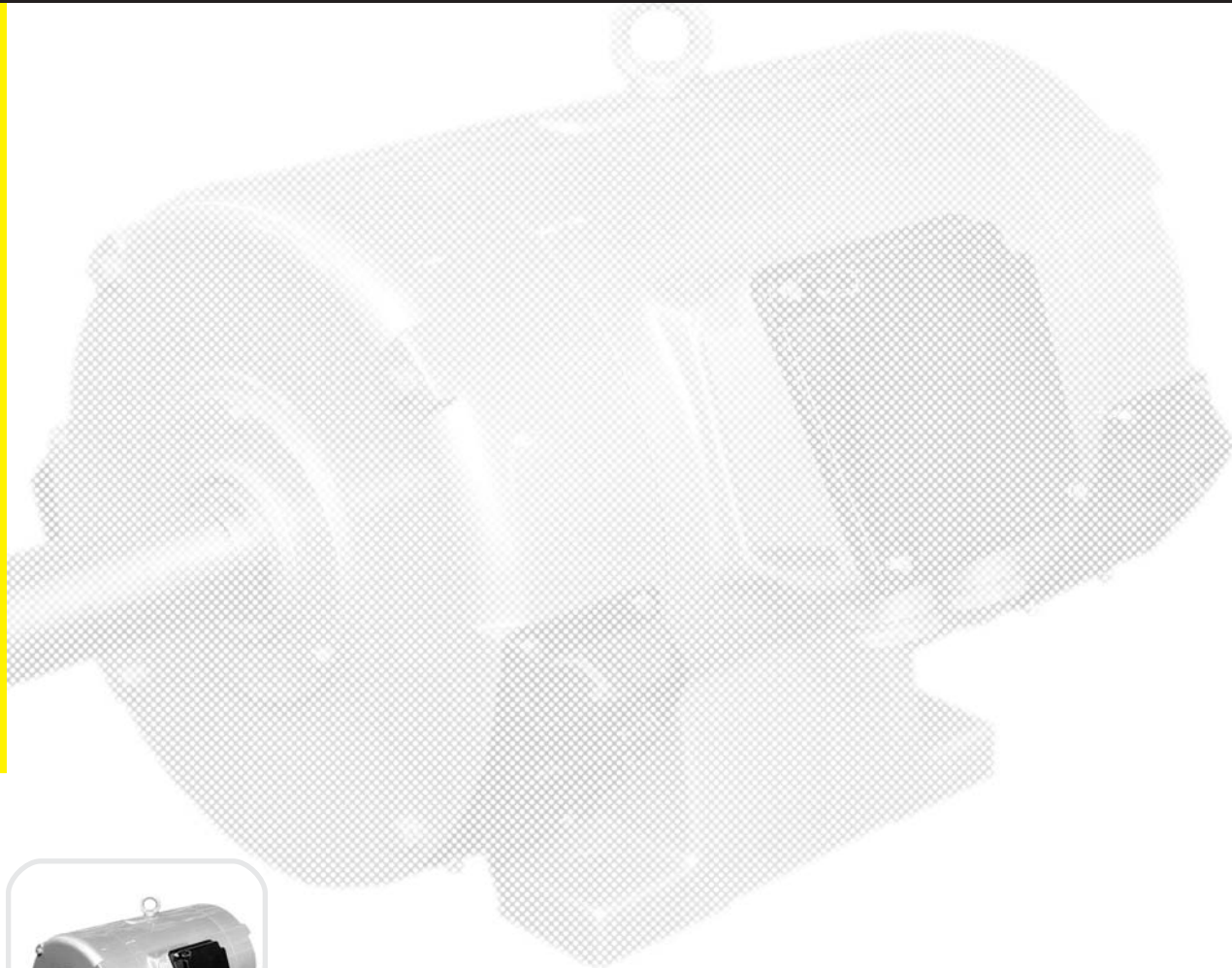

DRIP-PROOF ELECTRIC MOTORS  
type OK

OK09EN

# Vision



We set your ideas in motion. We do not merely manufacture motors, but instead turn the ambitious concepts of our customers into modern, innovative and reliable products, which are unique and point the way to the future. We bring our customers closer to their goals with reliability, creativity and flexibility.

## Business Units



Serial Motors



New Businesses



Home Appliances

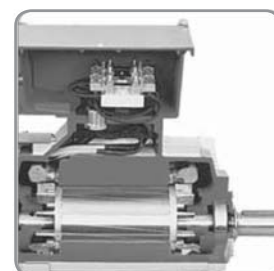

Project Motors

Type	P <sub>N</sub> kW	n min <sup>-1</sup>	h %	cos φ	I <sub>N</sub> A	M <sub>m</sub> Nm	I <sub>p</sub> /I <sub>N</sub>	M <sub>p</sub> /M <sub>N</sub>	M <sub>m</sub> /M <sub>N</sub>	RC	J kgm <sup>2</sup>	Mass kg
------	----------------------	------------------------	--------	-------	---------------------	----------------------	--------------------------------	--------------------------------	--------------------------------	----	-----------------------	------------

n=3000min <sup>-1</sup>												
OK 160 Mk-2	11	2870	84,0	0,85	22,8	37	4,9	2,2	2,5	16	0,025	100
OK 160 M-2	15	2890	87,0	0,86	29,0	50	5,8	2,3	2,6	16	0,033	110
OK 160 Lk-2	18,5	2900	88,0	0,87	35,0	61	6,3	2,7	2,7	16	0,044	135
OK 160 L-2	22	2915	90,0	0,87	40,6	72	6,5	2,8	2,8	16	0,052	145
OK 180 M-2	30	2915	87,5	0,86	57,5	98	5,5	2,3	2,8	13	0,080	163
OK 180 L-2	37	2925	89,0	0,87	69,0	121	6,2	2,3	2,7	13	0,103	185
OK 200 M-2	45	2930	90,0	0,86	84,0	146	6,2	2,7	3,0	13	0,154	250
OK 200 L-2	55	2940	91,0	0,87	100,0	178	8,5	3,4	3,5	13	0,193	275
OK 225 M-2	75	2946	91,0	0,89	134,0	243	6,8	2,1	3,0	13	0,300	350
OK 250 S-2	90	2935	91,0	0,87	164,0	293	5,5	2,3	2,5	13	0,471	450
OK 250 M-2	110	2935	91,0	0,87	201,0	358	5,2	2,3	2,5	13	0,565	500
OK 280 M-2	132	2957	92,5	0,89	231,0	426	7,3	2,2	3,1	13	0,846	620
OK 315 S-2	160	2955	93,0	0,89	279,0	517	7,3	2,1	3,0	10	1,309	800
OK 315 M-2	200	2961	92,5	0,86	363,0	645	6,7	2,2	3,0	10	1,636	890
OK 315 Md-2	250	2956	94,0	0,87	441,0	807	5,9	2,0	2,9	10	1,854	1010
OK 355 S-2	315	2972	94,0	0,88	550,0	1052	7,6	2,0	2,2	10	2,263	1300
OK 355 M-2	355	2972	94,3	0,88	618,0	1140	7,6	2,0	2,2	10	2,550	1430
OK 355 Md-2	400	2970	94,5	0,87	700,0	1290	7,7	1,9	2,2	10	2,874	1610

n=1500min <sup>-1</sup>												
OK 160 M-4	11	1460	87,0	0,80	23,0	72	5,0	2,0	2,4	16	0,047	110
OK 160 Lk-4	15	1452	87,5	0,80	31,0	99	5,4	2,3	2,5	16	0,063	130
OK 160 L-4	18,5	1460	88,5	0,80	38,0	121	5,3	2,2	2,3	16	0,075	140
OK 180 M-4	22	1460	88,0	0,82	44,0	144	5,7	2,7	2,2	16	0,155	180
OK 180 L-4	30	1463	89,0	0,81	60,0	196	6,3	3,5	3,1	16	0,212	217
OK 200 M-4	37	1465	90,0	0,82	73,0	241	4,7	2,1	2,1	13	0,270	270
OK 200 L-4	45	1465	90,0	0,80	90,3	293	4,9	2,1	2,1	13	0,330	285
OK 225 M-4	55	1480	92,5	0,84	102,0	355	7,2	2,6	2,8	13	0,529	375
OK 250 S-4	75	1474	90,0	0,83	144,0	486	5,6	2,1	2,6	13	0,705	450
OK 250 M-4	90	1475	91,0	0,81	176,0	583	5,7	2,5	2,7	13	0,845	560
OK 280 S-4	110	1478	92,0	0,88	196,0	711	6,1	2,1	2,5	13	1,145	600
OK 280 M-4	132	1478	92,5	0,88	234,0	853	6,0	2,1	2,5	13	1,418	630
OK 315 S-4	160	1478	93,2	0,89	279,0	1034	6,4	2,0	2,7	10	1,940	838
OK 315 M-4	200	1478	93,1	0,88	350,0	1292	6,1	1,8	2,5	10	2,304	925
OK 315 Md-4	250	1480	93,7	0,89	433,0	1613	6,0	2,0	2,7	10	2,700	925
OK 355 S-4	315	1485	94,5	0,88	547,0	2025	5,4	1,8	2,5	10	4,334	1350
OK 355 M-4	355	1485	94,7	0,88	615,0	2283	5,4	1,8	2,4	10	5,345	1480
OK 355 Md-4	400	1486	94,9	0,87	700,0	2570	5,6	1,8	2,5	10	6,025	1660

Type	P <sub>N</sub> kW	n min <sup>-1</sup>	h %	cos φ	I <sub>N</sub> A	M <sub>m</sub> Nm	I <sub>p</sub> /I <sub>N</sub>	M <sub>p</sub> /M <sub>N</sub>	M <sub>m</sub> /M <sub>N</sub>	RC	J kgm <sup>2</sup>	Mass kg
------	----------------------	------------------------	--------	-------	---------------------	----------------------	--------------------------------	--------------------------------	--------------------------------	----	-----------------------	------------

n=1000min <sup>-1</sup>												
OK 160 M-6	7,5	955	84,0	0,81	15,9	75	5,3	2,0	2,7	13	0,069	110
OK 160 L-6	11	960	86,0	0,79	23,4	109	6,1	2,5	3,2	13	0,092	140
OK 180 M-6	15	970	87,0	0,79	31,5	148	5,1	1,7	2,5	13	0,155	180
OK 180 L-6	18,5	972	88,5	0,80	37,7	182	6,1	1,9	2,9	13	0,212	220
OK 200 M-6	22	982	87,5	0,82	44,5	214	5,6	1,8	2,6	13	0,423	280
OK 200 L-6	30	982	88,5	0,82	59,7	292	5,8	1,9	2,6	13	0,517	300
OK 225 M-6	37	977	90,0	0,80	74,0	361	4,4	1,9	2,3	13	0,793	390
OK 250 S-6	45	982	91,0	0,86	83,0	437	6,3	2,2	2,7	13	1,091	450
OK 250 M-6	55	985	91,5	0,88	99,0	533	6,3	2,1	2,3	13	1,309	560
OK 280 S-6	75	982	91,0	0,81	147,0	729	5,6	1,8	2,8	13	1,698	610
OK 280 M-6	90	984	92,0	0,81	174,0	873	6,3	1,9	2,9	13	2,102	650
OK 315 S-6	110	981	92,5	0,83	207,0	1070	5,6	2,4	2,6	13	3,470	900
OK 315 M-6	132	981	93,0	0,83	247,0	1285	5,5	2,4	2,6	13	4,164	1020
OK 355 Sk-6	160	985	93,5	0,85	290,0	1551	5,4	1,6	2,2	13	6,595	1250
OK 355 S-6	200	986	93,5	0,86	360,0	1937	5,1	1,7	2,2	13	7,914	1320
OK 355 M-6	250	989	94,0	0,86	446,0	2414	4,9	1,4	2,4	13	10,312	1450
OK 355 Md-6	315	987	94,0	0,89	544,0	3048	6,4	2,4	2,4	13	12,231	1630

n=750min <sup>-1</sup>												
OK 160 Mk-8	4	710	79,0	0,70	10,4	54	4,0	1,7	2,4	10	0,052	110
OK 160 M-8	5,5	708	81,0	0,72	13,6	74	4,1	1,7	2,4	10	0,069	130
OK 160 L-8	7,5	710	82,0	0,72	18,4	101	4,2	1,8	2,4	10	0,092	150
OK 180 M-8	11	723	84,0	0,71	26,6	145	4,1	1,4	2,2	10	0,154	180
OK 180 L-8	15	722	87,0	0,69	36,0	198	4,4	1,6	2,4	10	0,215	200
OK 200 M-8	18,5	725	88,0	0,73	41,6	244	4,0	1,5	2,0	13	0,423	280
OK 200 L-8	22	725	88,0	0,73	49,5	290	4,0	1,5	2,1	13	0,518	290
OK 225 M-8	30	732	89,0	0,76	64,0	391	4,6	1,7	2,2	13	0,793	360
OK 250 S-8	37	732	90,0	0,75	79,0	483	4,9	1,9	2,3	13	1,091	470
OK 250 M-8	45	732	90,5	0,75	96,0	587	4,8	1,8	2,3	13	1,309	510
OK 280 S-8	55	733	90,5	0,76	115,0	717	4,6	1,5	2,1	13	1,698	600
OK 280 M-8	75	733	91,0	0,77	155,0	977	4,5	1,5	2,0	13	2,102	670
OK 315 S-8	90	736	92,0	0,79	178,0	1168	5,3	1,8	2,9	13	4,478	860
OK 315 M-8	110	736	93,5	0,80	212,0	1427	6,4	1,8	3,0	13	5,200	1000
OK 355 Sk-8	132	736	93,2	0,80	254,0	1712	4,9	1,6	2,2	13	8,279	1330
OK 355 S-8	160	742	93,7	0,77	321,0	2059	4,3	1,7	2,7	13	9,935	1400
OK 355 M-8	200	741	93,8	0,77	396,0	2577	4,4	1,8	2,2	13	11,866	1510
OK 355 Md-8	250	741	94,4	0,79	484,0	3222	4,7	2,4	2,6	13	14,074	1690

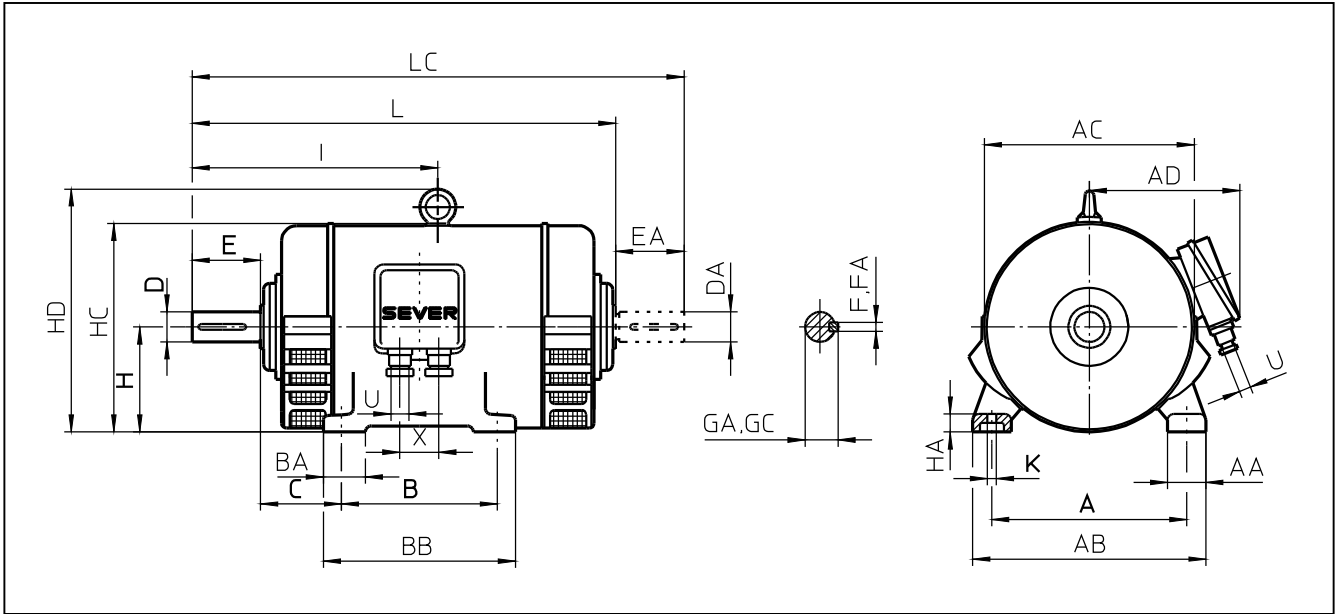

All dimensions in millimeters.

Type	Numb of poles	A	AA	AB	AC	AD	B	BA	BB	C	D	DA	E	EA	F	GA	H	HA	HC	HD	I	K	L	LC	U	X	
OK 160	M;Mk	2;4;6;8	254	60	314	306	210	67	260	108	48	48	110	110	14	51,5	160	25	320	382	388	15	662	772	Au 36x27	70	
	L;Lk																				413,5		713	823			
OK 180	M	2;4;6;8	279	70	349	352	241	82	296	121	55	55	110	110	16	59	180	30	360	422	415	15	720	830	Au 36x27	70	
	L																				435		760	870			
OK 200	M	2;4;6;8	318	80	398	394	267	95	337	133	60	60	140	140	18	64	200	35	396	458	473,5	19	801	946	Au 36x27	70	
	L																				493,5		839	984			
OK 225	M	2	356	90	446	436	340	311	110	380	149	60	60	140	140	18	64	225	40	444	506	515	19	889	1029	Au 36x27	70
		4;6;8										65	65														
OK 250	S	2	406	110	446	482	362	311	120	392	168	65	65	140	140	18	69	250	40	492	563	532	24	922	1062	Au 36x27	70
		4;6;8										75	75														
OK 250	M	2	406	110	506	482	362	349	120	430	168	65	65	140	140	18	69	250	40	492	563	550	24	958	1098	Au 36x27	70
		4;6;8										75	75														
OK 280	S	4;6;8	457	110	567	542	424	368	135	450	190	80	80	170	170	22	85	280	45	554	644	598	24	1024	1196	Au 42x42	80
	M	2										65	65														
		4;6;8	457	110	567	542	424	419	135	500	190	80	80	170	170	22	85	280	45	554	644	590,5	24	1039	1181	Au 42x42	80
OK 315	S	2	508	125	633	604	462	406	150	500	216	70	70	140	140	20	74,5	315	50	620	710	608	28	1073	1215	Au 42x42	80
		4;6;8										90	90									95					
OK 315	M;Md	2	508	125	633	604	462	457	150	550	216	70	70	140	140	20	74,5	315	50	620	710	638	28	1133	1275	Au 42x42	80
		4;6;8										90	90									95					
OK 355	S;Sk	2	610	140	750	684	574	500	140	600	254	75	75	140	140	20	79,5	355	50	706	834	724	28	1305	1445	Double cable inlet	
		4;6;8										100	100									106					
OK 355	M;Md	2	610	140	750	684	574	560	140	660	254	75	75	140	140	20	79,5	355	50	706	834	754	28	1365	1505	Double cable inlet	
		4;6;8										100	100									106					

The fixing dimensions given in thick figures are obligatory according to the recommendations of IEC. All the other technical data and dimensions of the motors type OK may undergo some changes during the further development of these motors and therefore they can be considered as obligatory after our confirmation only.

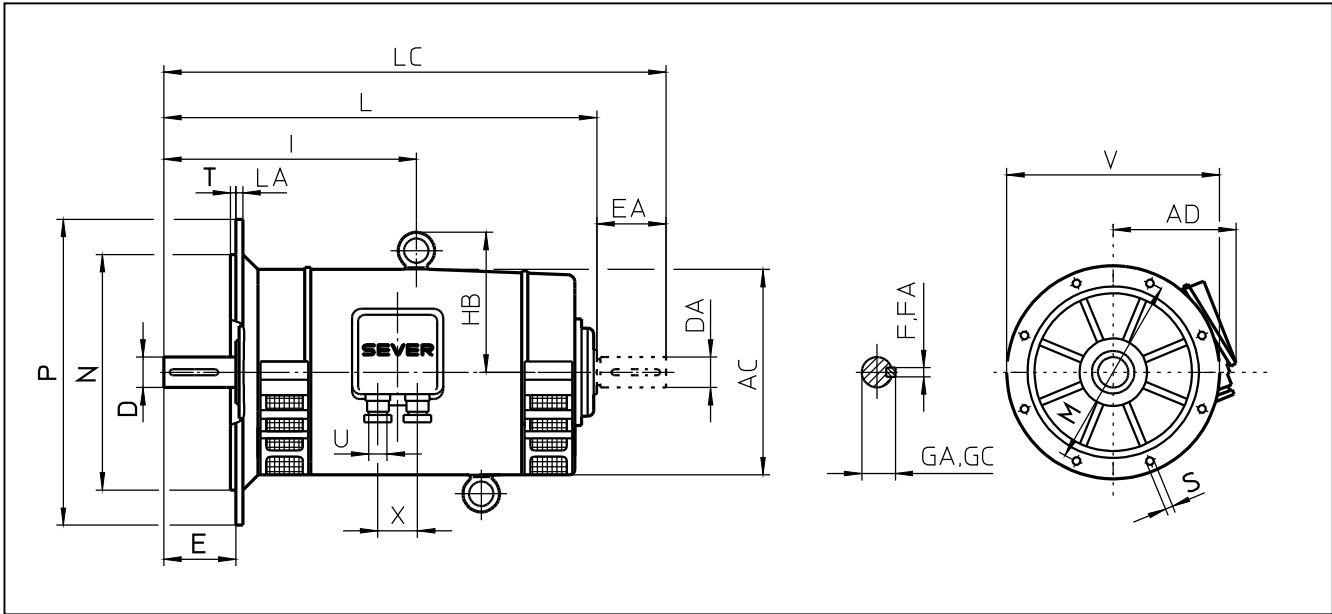

All dimensions in millimeters.

Type	Numb of poles	Flange designation	AC	AD	D	DA	E	EA	F FA	GA GC	HB	I	L	LA	LC	M	N	P	S	Num of holes	T	V	U	X
OK 160	M;Mk	F 300-I	306	293	48	48	110	110	14	51,5	221	388	662	13	772	300	250	350	18	8	5	468	Au 36x27	70
	L;Lk											413,5	713		823									
OK 180	M	F 400-I	352	288	55	55	110	110	16	59	242	415	720	22	830	400	350	450	19	8	5	513	Au 36x27	70
	L											435	760		870									
OK 200	M	F 500-I	394	317	60	60	140	140	18	64	262	473,5	801	22	946	500	450	550	19	8	5	592	Au 36x27	70
	L											493,5	839		984									
OK 225	M	F 500-I	436	340	60	60	140	140	18	64	287	515	889	22	1029	500	450	550	19	8	5	615	Au 36x27	70
					4;6;8	65																		
OK 250	S	F 600-I	482	362	65	65	140	140	18	69	321	532	922	25	1062	600	550	660	24	8	6	692	Au 36x27	70
					4;6;8	75																		
	M	F 600-I	482	362	65	65	140	140	18	69	321	550	958	25	1098	600	550	660	24	8	6	692	Au 36x27	70
	4;6;8			75	75			20	79,5															

The fixing dimensions given in thick figures are obligatory according to the recommendations of IEC. All the other technical data and dimensions of the motors type OK may undergo some changes during the further development of these motors and therefore they can be considered as obligatory after our confirmation only.

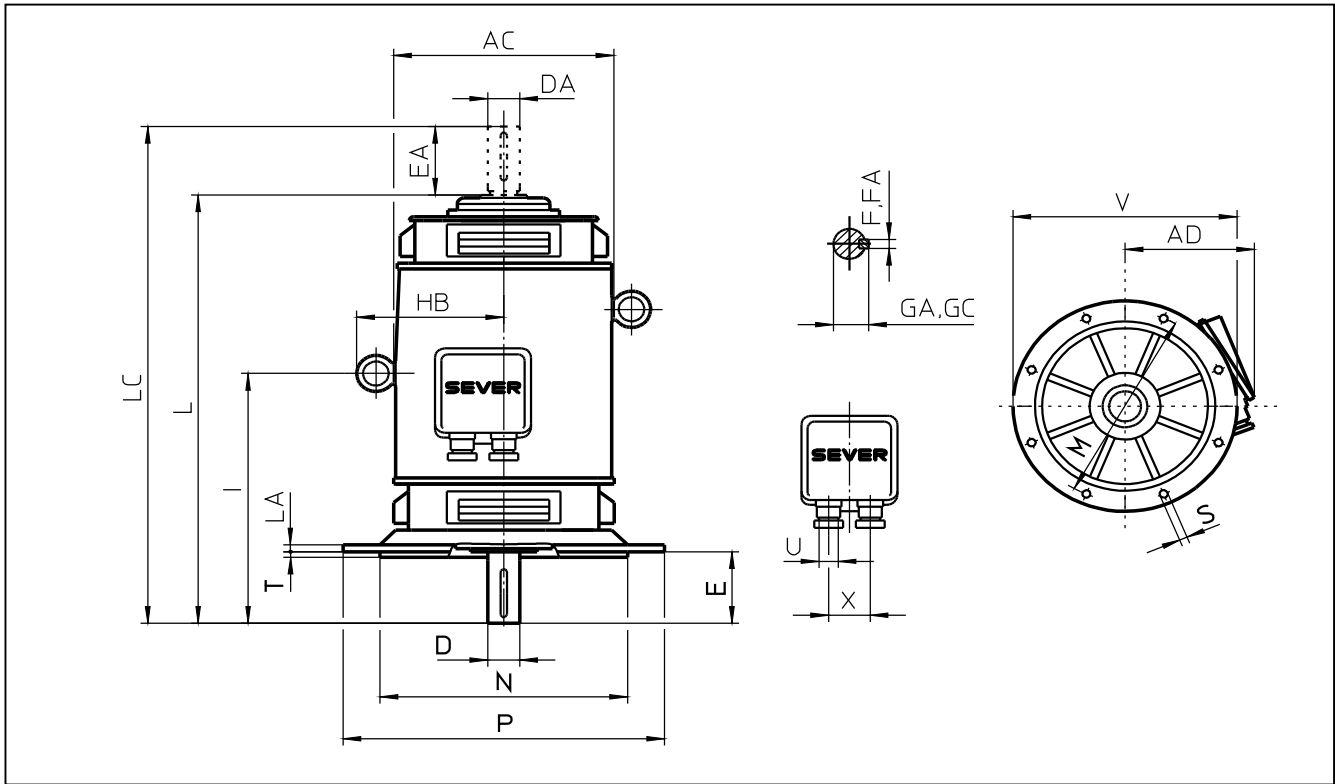

All dimensions in millimeters.

Type	Numb of poles	Flange designation	AC	AD	D	DA	E	EA	F FA	GA GC	HB	I	L	LA	LC	M	N	P	S	Num of holes	T	V	U	X
OK 160 M;Mk L;Lk	2;4;6;8	F 300-I	306	293	48	48	110	110	14	51,5	221	388	662	13	772	300	250	350	18	8	5	468	Au 36x27	70
												413,5	713	823										
OK 180 M L	2;4;6;8	F 400-I	352	288	55	55	110	110	16	59	242	415	720	22	830	400	350	450	19	8	5	513	Au 36x27	70
												435	760	870										
OK 200 M L	2;4;6;8	F 500-I	394	317	60	60	140	140	18	64	262	473,5	801	22	946	500	450	550	19	8	5	592	Au 36x27	70
												493,5	839	984										
OK 225 M	2	F 500-I	436	340	60	60	140	140	18	64	287	515	889	22	1029	500	450	550	19	8	5	615	Au 36x27	70
	4;6;8				65	65																		
OK 250 S M	2	F 600-I	482	362	65	65	140	140	18	69	321	532	922	25	1062	600	550	660	24	8	6	692	Au 36x27	70
	4;6;8				75	75																		
OK 250 M	2	F 600-I	482	362	65	65	140	140	18	69	321	550	958	25	1098	600	550	660	24	8	6	692	Au 36x27	70
	4;6;8				75	75																		
OK 280 S M	2	F 600-I	542	424	80	80	170	170	22	85	364	598	1024	25	1196	600	550	660	24	8	6	754	Au 42x42	80
	4;6;8				65	65																		
OK 280 M	2	F 600-I	542	424	80	80	170	170	22	85	364	590,5	1039	25	1181	600	550	660	24	8	6	754	Au 42x42	80
	4;6;8				620,5	1069						1241												
OK 315 S	2	F 600-I	604	462	70	70	140	140	20	74,5	395	608	1073	25	1215	740	680	800	24	8	6	862	Au 42x42	80
	4;6;8				90	90																		
OK 315 M;Md	2	F 740-I	604	462	70	70	140	140	20	74,5	395	638	1133	25	1275	740	680	800	24	8	6	862	Au 42x42	80
	4;6;8				90	90																		
OK 355 S;Sk	2	F 740-I	684	574	75	75	140	140	20	79,5	479	724	1305	25	1445	740	680	800	24	8	6	974	Double cable inlet	70
	4;6;8				100	100																		
OK 355 M;Md	2	F 740-I	684	574	75	75	140	140	20	79,5	479	754	1365	25	1505	740	680	800	24	8	6	974	Double cable inlet	70
	4;6;8				100	100																		

The fixing dimensions given in thick figures are obligatory according to the recommendations of IEC. All the other technical data and dimensions of the motors type OK may undergo some changes during the further development of these motors and therefore they can be considered as obligatory after our confirmation only.

## SELECTION OF BEARINGS FOR OPEN CAGE MOTORS

Type	Numb of poles	Horizontal shaft		Vertical shaft		Quantity of grease (gr)	Time of	
		D-end	No D-end	D-end	No D-end		Number of poles 2	4, 6, 8
<b>OK 160</b>	2,4,6,8	6310 C3	6310 C3	6310 C3	6310 C3	31	10 000	20 000
<b>OK 180</b>	2,4,6,8	6312 C3	6312 C3	6312 C3	6312 C3	40	10 000	20 000
<b>OK 200</b>	2,4,6,8	6313 C3	6313 C3	6313 C3	6313 C3	47	10 000	20 000
<b>OK 225</b>	2,4,6,8	6314 C3	6314 C3	6314 C3	6314 C3	27	2 500	5 900
<b>OK 250</b>	2,4,6,8	6316 C3	6316 C3	6316 C3	6316 C3	31	2 100	5 700
<b>OK 280</b>	2,4,6,8	6317 C3	6317 C3	6317 C3	6317 C3	37	1 900	5 200
<b>OK 315</b>	2,4,6,8	6319 C3	6319 C3	6319 C3	7319 B	45	1 700	5 200
<b>OK 355</b>	2	6319 C3	6319 C3	6319 C3	7319 B	45	1 700	
	4,6,8	6322 C3	6322 C3	6322 C3	7322 B	60		4350

# QUESTIONNAIRE FOR THE OFFER OF ASYNCHRONOUS ELECTRIC MOTORS



Enquiry Number: \_\_\_\_\_

Customer: \_\_\_\_\_ ITEM: \_\_\_\_\_  
Qty: \_\_\_\_\_

**A MOTOR DATA**

1 Motor type: Three phase: \_\_\_\_\_ Single phase: \_\_\_\_\_

2 Rotor type: Squirrel cage: \_\_\_\_\_ Slip-ring: \_\_\_\_\_

3 Rated output:  $P_N =$  \_\_\_\_\_ kW

4 Rated voltage:  $U_N =$  \_\_\_\_\_ V Connect: Star \_\_\_\_\_ Delta \_\_\_\_\_

5 Rated frequency:  $f_N =$  \_\_\_\_\_ Hz

6 Rated speed:  $n_N =$  \_\_\_\_\_ rpm

7 Insulation class: F  B

8 Duty type: S1 S2 S3 S4 S5 S6 S7 S8 S9 S10  
ED % 

--	--	--	--	--	--	--	--	--	--	--

  
starts /h \_\_\_\_\_ min \_\_\_\_\_  $J_{mot}$  \_\_\_\_\_ kgm<sup>2</sup>

9 Standard: \_\_\_\_\_ IEC or \_\_\_\_\_

10 Cooling method: \_\_\_\_\_ IC

11 Mounting arrangement: IM

12 Protection degree: Motor IP: \_\_\_\_\_ Terminal box IP: \_\_\_\_\_

13 \*Sense of rotation: Left \_\_\_\_\_ Right \_\_\_\_\_ Both \_\_\_\_\_

14 Motor brake: yes  no   
Braking moment: \_\_\_\_\_ Nm  
Brake voltage: \_\_\_\_\_ V/Hz \_\_\_\_\_ V,DC

15 No-load regime? (single phase motor) yes \_\_\_\_\_ no \_\_\_\_\_

16 Rotor data:  $U_{2c} =$  \_\_\_\_\_ V  $I_{2n} =$  \_\_\_\_\_ A

**B DATA ABOUT THE DRIVEN MACHINE**

1 Type: \_\_\_\_\_

2 Required power: \_\_\_\_\_

3 Required speed: \_\_\_\_\_

4 Load torque characteristic:  
Constant: \_\_\_\_\_ Squared \_\_\_\_\_ or \_\_\_\_\_  
Speed %: 

0	25	50	75	100
---	----	----	----	-----

  
Torque Nm: 

--	--	--	--	--

5 Moment of inertia:  $J =$  \_\_\_\_\_ kgm<sup>2</sup>

6 Running machine special data: \_\_\_\_\_

**C AMBIENT CONDITIONS**

1 Ambient temperature: \_\_\_\_\_ C

2 Relative humidity: \_\_\_\_\_ %

3 Altitude [above sea level]: \_\_\_\_\_ m

4 Specific ambient conditions: \_\_\_\_\_

**D POWER TRANSMISSION AND STARTING CONDITIONS**

1 Coupling type: \_\_\_\_\_

2 Starting: \_\_\_\_\_

3 Number of consecutive startings:  
Hot state: \_\_\_\_\_ Cold state: \_\_\_\_\_  
\_\_\_\_\_ per hour \_\_\_\_\_ per hour  
\_\_\_\_\_ per day \_\_\_\_\_ per day

**E ADDITIONAL REQUESTS FOR MOTOR EXECUTION**

1 Overloading from: \_\_\_\_\_ %  $P_N$   
Duration: \_\_\_\_\_ min

2 Temperature rise: F  B

3 Request for: vibration level \_\_\_\_\_ mm/s  
noise level \_\_\_\_\_ db

4 \*Terminal box position:  
left  right  On top

5 Additional shaft loading sense  
axial force \_\_\_\_\_ radial force \_\_\_\_\_

6 Converter feed operation: yes  no   
Converter type: \_\_\_\_\_  
Manufacturer: \_\_\_\_\_  
Speed range: from \_\_\_\_\_ to \_\_\_\_\_ rpm

7 Sensor category (mark in lower field):  
Taho gen. \_\_\_\_\_ Encoder \_\_\_\_\_ Absolute \_\_\_\_\_ Resolver \_\_\_\_\_  
Sensor Type: \_\_\_\_\_

8 Flange size: \_\_\_\_\_ mm

9 Second shaft end: yes  no   
DA= \_\_\_\_\_ mm EA= \_\_\_\_\_ mm

10 Other requests and limits: \_\_\_\_\_

**F ADDITIONAL EQUIPMENT, SPARE PARTS AND DOCUMENTATION**

1 Thermal protection: yes  no   
Type: \_\_\_\_\_

2 Bearings thermometers yes  no

3 Anti-condensation heaters yes  no

4 Spare parts yes  no

5 Guarantee sheet yes  no

6 Language of instruction list: \_\_\_\_\_

7 Other requests for packing: \_\_\_\_\_

You are kindly requested to provide us with as much data as possible thus enabling us to offer satisfactorily

**H CUSTOMER**

1 Company: \_\_\_\_\_

2 Address: \_\_\_\_\_

3 City: \_\_\_\_\_

4 Country: \_\_\_\_\_

5 Person: \_\_\_\_\_

6 Telefon / Telefax: \_\_\_\_\_

7 e-mail: \_\_\_\_\_

## Company locations

### HEAD OFFICE AUSTRIA

#### ATB Austria Antriebstechnik AG

Renngasse 6-8  
1010 Wien, Austria

T: +43 1 90 250 - 0  
F: +43 1 90 250 110

info@atb-motors.com  
www.atb-motors.com

### AUSTRIA

#### ATB Motorenwerke GmbH

G.-Bauknecht-Str. 1  
8724 Spielberg  
T: +43 3577 757-323  
F: +43 3577 757-182  
info@atb-motors.com

#### ATB Technologies GmbH

Millenium Park 11  
6890 Lustenau  
T: +43 5577 9010-0  
F: +43 5577 9010-110  
info@atb-motors.com

### ASIA

#### ATB Motorentechnik GmbH

141 Market Street,  
# 07-01 International Factors  
Building  
Singapore 048944  
T: +65 63721174  
F: +65 62253524  
dennis.tan@atbs.com.sg

### BAHREIN

#### ATB Austria Antriebstechnik Aktiengesellschaft, Rep. Office Bahrain

Almoayyed Tower  
21st Floor c/o Regus  
Seef District, Manama  
Kingdom of Bahrain  
T: +973 175 68 160  
F: +973 175 67 901

### BENELUX

#### ATB BeNeLux B.V.

Tasveld 14  
8271 RW IJsselmuiden  
T: +31 38 443 2110  
F: +31 38 443 2111  
verkoop@nl.atb-motors.com

### GERMANY

#### ATB Antriebstechnik GmbH

Silcherstraße 74  
73642 Welzheim  
T: +49 7182 14-535  
F: +49 7182 14 590  
info@de.atb-motors.com

#### ATB Motorentechnik GmbH

Helgoländer Damm 75  
26954 Nordenham  
T: +49 4731 365-0  
F: +49 4731 365-159  
info@de.atb-motors.com

#### Schorch Elektrische Maschinen und Antriebe GmbH

Breite Straße 131  
41238 Mönchengladbach  
T: +49 2166 925-0  
T: +49 2166 925-100  
mail@schorch.de

### POLAND

#### Fabryka Silników Elektrycznych Tamel S.A.

ul. Elektryczna 6  
33 100 Tarnow  
T: +48 14 632 11 00  
F: +48 14 632 11 02  
officetamel@tamel.pl

### RUSSIA

#### ATB Rus 000

Petrovka ul. 27  
107031 Moscow  
T: +7 495 95 66 326  
vyacheslav.mikheyev@tecindustries.com

### SERBIA

#### ATB SEVER D00 SUBOTICA

Magnetna polja 6  
24000 Subotica  
T: +381 24 665 100  
F: +381 24 546 893  
sever@rs.atb-motors.com

#### ATB FOD d.o.o.

Dorda Vajfert 16  
19210 Bor  
T: +381 30 423 147  
fod@fod.co.rs

### SWITZERLAND

#### ATB Schweiz AG

Industriestraße 28  
5600 Lenzburg  
T: +41 62 885 70-10  
info@ch.atb-motors.com

### UK & IRELAND

#### ATB Laurence Scott Ltd.

PO Box 25 Hardy Road, Norwich NR1 1JD  
Norfolk  
T: +44 1603 628 333  
hvm.sales@laurence-scott.com

#### ATB Morley Limited

Bradford Road  
Leeds LS28 6QA  
West Yorkshire  
T: +44 113 257 1734  
sales@uk.atb-motors.com

#### Brook Crompton UK

St. Thomas Road, Huddersfield HD1 3LJ  
West Yorkshire  
T: +44 1484557200  
F: +44 1484557201  
csc@brookcrompton.com

### CANADA

#### Brook Crompton

North America  
264 Attwell Drive  
M9W 5B2 Toronto, Ontario  
T: +1 416 675-3844  
ramzi.mallouk@brookcromptonna.com

**ATB SEVER DOO SUBOTICA**

Magnetna polja 6

24 000 Subotica

Serbia

Tel. +381 24 665-124

Fax +381 24 665-125

[www.atb-motors.com](http://www.atb-motors.com)

[sever@rs.atb-motors.com](mailto:sever@rs.atb-motors.com)