

Technical Documentation



TOTALLY ENCLOSED SLIPRING
MOTORS FOR CRANES type ZPD

ZPD08EN

Vision



We set your ideas in motion. We do not merely manufacture motors, but instead turn the ambitious concepts of our customers into modern, innovative and reliable products, which are unique and point the way to the future. We bring our customers closer to their goals with reliability, creativity and flexibility.

Business Units



Serial Motors



New Businesses



Home Appliances

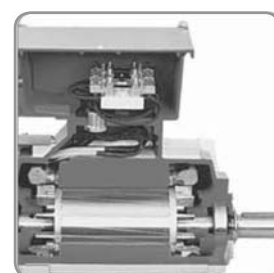

Project Motors

The totally enclosed fan cooled slipring electromotors type ZPD are specially designed for driving cranes also for intermittent periodic duty, for hard starting conditions, speed control and dirty ambient. For these reasons they have special electrical and mechanical characteristics which are accommodate to the peculiar working conditions. The principal dimensions of these motors comply with the recommendations of the I. E. C. publication 72 fifth edition. They also comply with the prescriptions DIN 42681 and SEB 841 101-70 (Stahl-Eisen-Betriebsblätter). Owing their small dimensions they easily find their place in every construction and replace without difficulties electromotors of older construction. Also, they are very economical, reliable and need very simple servicing.

I MECHANICAL ARRANGEMENTS

Construction and shape

Frames and endshields of all motors included in this leaflet are made of cast iron. The frames are provided with radial cooling ribs equally distributed over the whole circumference and length of the frames. All components are mechanically so dimensioned that they endure the strongest mechanical employment to which motors can be exposed (the performances of these motors meet the requirements of the standard SEB 841 101-70 for cast iron frames). These motors are produced in three essential shapes B3, B5 and V1. The quoted shapes are in accordance with prescriptions DIN 42950. On the request the motors may be delivered in the combined shape B3/B5.

Cooling

The motors are cooled by an external fan, that is provided with a fan cover. The fan blows the cooling-air equally along the whole outer circumference of the motor independently from the rotation-sense of the motor. The fans are made with blades of aerodynamical profile, providing a noiseless circulation of the cooling air.

Mechanical protection

The motors type ZPD are constructed as totally enclosed, class of protection IP44 (I. E. C. publication 34-5, 1968 or Din 40050). The parts under tension and the inner rotating ones are protected against the ingress of solid foreign bodies whose smallest dimension exceeds 1 mm and against spray and drip water without special pressure from all directions. They are also protected against penetration of heavy dust.

Insulation of the windings

The windings of the stator are insulated according to insulation class "B". The temperature rise is 80K supposed that the ambient temperature does not exceed 40°C (according to I. E. C. recommendations and VDE 0530). The windings of the rotor are insulated according to insulation class "F". The allowed temperature rise for this class is 100K when the ambient temperature does not exceed 40°C. Both temperature rises refer to a measuring by increased resistance. For manufacturing windings insulation according to other prescriptions, please consult the factory with a special inquiry.

Bearings

Types of bearings and its designations are given in the table 2. Types ZPD225 to ZPD400 have bearing caps which make lubrication possible while the motor is working. The superfluous grease is eliminated by a regulating ring. The penetration of grease into the inside of the motor is prevented by felt rings. The bearings are so dimensioned that they endure 20.000 working hours.

Terminal box

The motors are produced with terminal box on the top of the frame. The terminal box is provided with two cable-inlets or with the cable-head. The position of these cable-inlets can be on every side of the terminal box. On the request it is possible to add two cable-inlets, one for earthing and the second for control unit (thermal protection). These cable-inlets are in accordance with VDE 9010 and they have a Pg winding according to DIN 40430.

Sliprings

The sliprings are on the drive-end and they are made of cast bronze. Admittance to the brushes is very easy by removing the cover of the terminal box. The brush holders and brushes can be complete replaced through the top side of the frame.

Noise and vibration

In purpose to decrease noise and vibration-quiet run-the rotor has been balanced on a high sensitive dynamic balancing machine. They have been balanced together with shaft key and fan. The motors are produced in the class of vibration N (DIN 45665). For class of vibration R (reduced) or S (special) please consult the factory. The noise level of our motors is below the sound intensity level accepted by various commissions, and it also complies with standard VDE 0530.

Shaft ends

The motors are produced with one free shaft end (cylindrical). On special request they can be delivered also with two free shaft ends (cylindrical or conical). Cylindrical shaft end is manufactured in accordance with prescription ISO/R773, and conical with ISO/R775.

II ELECTRICAL CHARACTERISTICS

Voltage and frequency

The motors are standardly executed for a rated voltage 380 V (star-connection) and rated frequency 50 Hz. On request the motors may be executed for other voltage between 110 and 660 V as well as for a frequency between 40 and 60 Hz. The motors produced for a rated voltage 380 V, 50 Hz may be applied for voltage 440 V, 60 Hz.

The winding of rotor is coupled in star-connection also. The rotor voltage is in accordance with DIN 42681 and it can differ for $\pm 15\%$.

Output

The rated powers given in schedules are valid for intermittent duty type S3 (a sequence of identical duty cycles each including a period of operation at constant load and a rest de-energized period-IEC publication 34-1) for the cyclic duration factor 25, 40, 60 and 100%. The powers for the cyclic duration factor 100% comply with IEC publ.72 - 1971.

The values given in Data Sheets are valid for the following conditions:

- Rated voltage $\pm 5\%$
- Rated frequency -10%
- Height above sea level not exceeding 1000 m
- Temperature of the coolant not exceeding 40°C

For other conditions please consult our Construction bureau.

Speed

The motors type ZPD are produced as 4, 6, 8 and 10 pole motors with corresponding synchronous speeds 1500, 1000, 750 and 600 min^{-1} . The speeds given in Data Sheets are valid for the rated voltage, frequency, output and intermittent duty type S3. On request the motors can be delivered also for greater number of poles respectively for speeds less than 600 min^{-1}

Thermal protection

On request the motor can be provided with built in thermal protection. Choice of thermistor depends on the motor insulation, the motor design, the positioning of thermistors in the windings and the normal operating temperature of the motor. Generally 130°C thermistors are used for a class B motor. When warning of impending overheat is required a separate set of thermistors is used usually with reference temperatures 10K lower than the protection thermistors. For this kind of thermal protection the PTC thermistors are used. On special request motors can be delivered with control unit.

The Units given in the schedules correspond to The International System of Units - SI units.

The International System of Units is in accordance with International Standard ISO 31/1975.

TOTALLY ENCLOSED SLIPRING MOTORS FOR CRANES type ZPD

Mechanical protection: IP 54/55

Voltage: 380 V, 50 Hz

Type	2p=4, 1500 min ⁻¹			S3, ED 100%, 6 starts/hour					S3, ED 60%, 6 starts/hour				
	Mass kg	J kgm ²	Rotor voltage U ₂ 10% V	Output power P _N kW	Rated speed n _N min ⁻¹	Rated current I _N A	$\frac{T_m}{T}$	Rotor current I ₂ A	Output power P _N kW	Rated speed n _N min ⁻¹	Rated current I _N A	$\frac{T_m}{T}$	Rotor current I ₂ A
ZPD 160 M -4	125	0.068	185	7.5	1430	17	3.1	25	8.5	1425	19	2.8	29
ZPD 160 L -4	160	0.08	265	11	1435	24.5	3.2	25	13	1430	29	3.0	29.5
ZPD 180 L -4	220	0.24	260	15	1455	31	4.0	35	17.5	1445	35	3.4	41
ZPD 200 Lk-4	290	0.36	220	18.5	1458	38	3.8	52	22	1450	44.7	3.1	62.8
ZPD 200 L -4	310	0.41	280	22	1460	44	4.0	50	26	1457	53	3.3	60
ZPD 225 M -4	440	0.7	330	30	1475	56.6	4.2	55	34	1470	63	3.9	62
ZPD 250 Mk-4	590	1.15	166	37	1473	71	4.0	137	44	1470	83	3.5	163
ZPD 250 M -4	640	1.35	200	45	1475	86	4.0	137	53	1472	98	3.4	162
ZPD 280 S-4	780	1.83	230	55	1475	105	3.8	147	64	1471	122	2.9	171
ZPD 280 M -4	870	2.23	310	75	1475	139	4.0	147	87	1470	160	3.4	171
ZPD 315 S-4	1010	3.05	275	90	1475	164	4.5	198	105	1472	190	3.9	231
ZPD 315 M -4	1115	3.72	335	110	1480	200	4.7	199	130	1477	234	4.1	235
ZPD 355 Lk-4	1515	5.72	340	132	1482	240	3.8	235	160	1478	285	3.2	285
ZPD 355 L -4	1655	7.42	440	160	1485	290	4.0	220	185	1483	330	3.5	254
ZPD 400 Lk-4	2030	11.24	610	200	1485	365	4.4	198	230	1483	415	3.8	228
ZPD 400 L-4	2320	14.06	760	250	1485	455	4.4	200	290	1483	520	3.8	232

Type	2p=4, 1500 min ⁻¹			S3, ED 40%, 6 starts/hour					S3, ED 25%, 6 starts/hour				
	Mass kg	J kgm ²	Rotor voltage U ₂ 10% V	Output power P _N kW	Rated speed n _N min ⁻¹	Rated current I _N A	$\frac{T_m}{T}$	Rotor current I ₂ A	Output power P _N kW	Rated speed n _N min ⁻¹	Rated current I _N A	$\frac{T_m}{T}$	Rotor current I ₂ A
ZPD 160 M -4	125	0.068	185	10	1415	22	2.5	34	11.5	1400	25	2.1	39
ZPD 160 L -4	160	0.08	265	15	1425	33	2.6	34	17.5	1410	40	2.2	40
ZPD 180 L -4	220	0.24	260	20	1436	39	3.0	47	23	1426	45	2.6	54
ZPD 200 Lk-4	290	0.36	220	25	1440	50	2.7	72	30	1430	60	2.2	88
ZPD 200 L -4	310	0.41	280	30	1450	60	2.9	69	35	1440	69	2.4	82
ZPD 225 M -4	440	0.7	330	40	1465	73.5	3.3	73	48	1457	88.6	2.7	88
ZPD 250 Mk-4	590	1.15	166	50	1465	92	3.0	186	60	1460	110	2.6	222
ZPD 250 M -4	640	1.35	200	63	1467	113	2.9	191	72	1462	128	2.5	220
ZPD 280 S-4	780	1.83	230	75	1466	145	2.5	200	85	1462	170	2.2	227
ZPD 280 M -4	870	2.23	310	100	1466	180	3.0	196	115	1460	208	2.6	226
ZPD 315 S-4	1010	3.05	275	120	1469	215	3.5	264	140	1465	250	3.0	308
ZPD 315 M -4	1115	3.72	335	155	1473	276	3.7	280	175	1472	310	3.2	316
ZPD 355 Lk-4	1515	5.72	340	175	1476	312	2.9	311	200	1473	350	2.5	356
ZPD 355 L -4	1655	7.42	440	220	1479	390	2.9	302	240	1477	430	2.6	330
ZPD 400 Lk-4	2030	11.24	610	270	1481	475	3.2	267	300	1479	525	2.9	297
ZPD 400 L-4	2320	14.06	760	340	1481	605	3.2	272	380	1477	660	2.8	304

TOTALLY ENCLOSED SLIPRING MOTORS FOR CRANES type ZPD

Mechanical protection: IP 54/55
Voltage: 380 V, 50 Hz

Type	2p=4, 1500 min ⁻¹			S4, S5, ED 25%, 150 starts/hour				S4, S5, ED 40%, 150 starts/hour					
	Mass kg	J kgm ²	Rotor voltage U ₂ 10% V	Output power P _N kW	Rated speed n _N min ⁻¹	Rated current I _N A	$\frac{T_m}{T}$	Rotor current I ₂ A	Output power P _N kW	Rated speed n _N min ⁻¹	Rated current I _N A	$\frac{T_m}{T}$	Rotor current I ₂ A
ZPD 160 M -4	125	0.068	185	9.5	1418	21	2.6	32.5	8.5	1425	19	2.8	29
ZPD 160 L -4	160	0.08	265	14	1247	31	2.8	32	12.5	1432	28	3.0	29
ZPD 180 L -4	220	0.24	260	19	1440	37	3.2	44	17	1446	34	3.5	40
ZPD 200 Lk-4	290	0.36	220	23	1450	46.4	3.0	66	21	1452	43	3.2	60
ZPD 200 L -4	310	0.41	280	27	1455	54.5	3.2	62	25	1460	51	3.4	57
ZPD 225 M -4	440	0.7	330	37	1467	68	3.6	68	33	1471	61	4.0	60.5
ZPD 250 Mk-4	590	1.15	166	46	1470	86	3.2	170	41	1472	78	3.6	152
ZPD 250 M -4	640	1.35	200	56	1470	103	3.2	170	50	1474	93	3.6	152
ZPD 280 S-4	780	1.83	230	68	1470	130	2.8	182	60	1473	114	3.1	160
ZPD 280 M -4	870	2.23	310	94	1468	170	3.2	184	85	1470	156	3.5	166
ZPD 315 S-4	1010	3.05	275	112	1471	201	3.6	246	100	1473	187	4.0	220
ZPD 315 M -4	1115	3.72	335	137	1476	245	3.8	248	122	1478	221	4.2	221
ZPD 355 Lk-4	1515	5.72	340	165	1477	295	3.1	294	148	1480	265	3.4	263
ZPD 355 L -4	1655	7.42	440	200	1481	355	3.2	275	180	1483	325	3.6	248
ZPD 400 Lk-4	2030	11.24	610	250	1482	445	3.5	247	224	1484	405	3.9	222
ZPD 400 L -4	2320	14.06	760	312	1482	555	3.5	250	280	1484	505	3.9	224

Type	2p=4, 1500 min ⁻¹			S4, S5, ED 60%, 150 starts/hour				S4, S5, ED 40%, 300 starts/hour					
	Mass kg	J kgm ²	Rotor voltage U ₂ 10% V	Output power P _N kW	Rated speed n _N min ⁻¹	Rated current I _N A	$\frac{T_m}{T}$	Rotor current I ₂ A	Output power P _N kW	Rated speed n _N min ⁻¹	Rated current I _N A	$\frac{T_m}{T}$	Rotor current I ₂ A
ZPD 160 M -4	125	0.068	185	7.5	1430	17	3.1	25	7.5	1430	17	3.1	25
ZPD 160 L -4	160	0.08	265	11	1435	24.5	3.2	25	10.5	1440	24	3.3	24
ZPD 180 L -4	220	0.24	260	15	1445	31	4.0	35	14.5	1454	30	4.1	34
ZPD 200 Lk-4	290	0.36	220	18.5	1450	38	3.8	52	18	1460	38	3.9	51
ZPD 200 L -4	310	0.41	280	22	1460	44	4.0	50	21	1465	45	4.1	47.5
ZPD 225 M -4	440	0.7	330	30	1475	56.3	4.4	55	28	1476	53	4.7	51.4
ZPD 250 Mk-4	590	1.15	166	37	1470	71	4.2	137	35	1472	65	4.5	129
ZPD 250 M -4	640	1.35	200	45	1475	86	4.0	137	42	1478	81	4.3	128
ZPD 280 S-4	780	1.83	230	55	1475	105	3.4	147	54	1476	103	3.5	144
ZPD 280 M -4	870	2.23	310	75	1475	140	4.0	147	74	1474	138	4.1	145
ZPD 315 S-4	1010	3.05	275	90	1475	164	4.5	198	86	1476	165	4.6	189
ZPD 315 M -4	1115	3.72	335	110	1480	200	4.7	199	103	1481	191	4.8	186
ZPD 355 Lk-4	1515	5.72	340	132	1482	240	3.8	235	126	1483	230	4.0	224
ZPD 355 L -4	1655	7.42	440	160	1485	290	4.0	220	153	1486	280	4.2	210
ZPD 400 Lk-4	2030	11.24	610	200	1485	365	4.4	198	192	1486	355	4.6	190
ZPD 400 L -4	2320	14.06	760	250	1485	455	4.4	200	240	1486	435	4.6	192

TOTALLY ENCLOSED SLIPRING MOTORS FOR CRANES type ZPD

Mechanical protection: IP 54/55

Voltage: 380 V, 50 Hz

Type	2p=4, 1500 min ⁻¹			S4, S5, ED 60%, 300 starts/hour					S4, S5, ED 60%, 600 starts/hour				
	Mass kg	J kgm ²	Rotor voltage U ₂ 10% V	Output power P _N kW	Rated speed n _N min ⁻¹	Rated current I _N A	$\frac{T_m}{T}$	Rotor current I ₂ A	Output power P _N kW	Rated speed n _N min ⁻¹	Rated current I _N A	$\frac{T_m}{T}$	Rotor current I ₂ A
ZPD 160 M -4	125	0.068	185	6.5	1440	16	3.8	22	5	1460	13.8	4.8	17
ZPD 160 L -4	160	0.08	265	9.5	1450	22.5	4.0	22	7	1465	19	5.2	16
ZPD 180 L -4	220	0.24	260	13	1460	28	4.6	30	10	1470	24	6.0	23
ZPD 200 Lk-4	290	0.36	220	15	1465	33.5	4.5	42	12	1473	30	5.5	33.6
ZPD 200 L -4	310	0.41	280	19	1470	42	4.6	43	14.5	1477	35.7	5.8	32.8
ZPD 225 M -4	440	0.7	330	25	1480	48	5.3	46	19	1485	39.2	7.0	35
ZPD 250 Mk-4	590	1.15	166	31	1478	64	4.6	115	24	1480	55	6.0	89
ZPD 250 M -4	640	1.35	200	38	1480	75	4.8	116	29	1485	63	6.2	88
ZPD 280 S-4	780	1.83	230	50	1477	97	3.7	134	35	1483	74	5.3	94
ZPD 280 M -4	870	2.23	310	68	1476	128	4.4	133	51	1481	104	5.9	100
ZPD 315 S-4	1010	3.05	275	78	1478	152	4.9	172	59	1483	124	6.3	130
ZPD 315 M -4	1115	3.72	335	94	1483	177	5.1	170	70	1488	142	6.5	127
ZPD 355 Lk-4	1515	5.72	340	113	1484	215	4.5	201	86	1488	170	5.8	153
ZPD 355 L -4	1655	7.42	440	138	1487	255	4.6	190	104	1490	205	6.1	143
ZPD 400 Lk-4	2030	11.24	610	172	1488	325	5.1	170	130	1490	260	6.8	129
ZPD 400 L-4	2320	14.06	760	215	1488	405	5.1	172	163	1490	320	6.8	130

Type	2p=4, 1500 min ⁻¹			S2, 60 min					S2, 30 min				
	Mass kg	J kgm ²	Rotor voltage U ₂ 10% V	Output power P _N kW	Rated speed n _N min ⁻¹	Rated current I _N A	$\frac{T_m}{T}$	Rotor current I ₂ A	Output power P _N kW	Rated speed n _N min ⁻¹	Rated current I _N A	$\frac{T_m}{T}$	Rotor current I ₂ A
ZPD 160 M -4	125	0.068	185	8.7	1424	19.5	2.7	30	9.5	1418	21	2.6	32.5
ZPD 160 L -4	160	0.08	265	13	1430	29	3.0	29.5	14	1427	31	2.8	32
ZPD 180 L -4	220	0.24	260	18	1444	36	3.3	42	20	1436	39	3.0	47
ZPD 200 Lk-4	290	0.36	220	22.5	1448	45.5	3.0	64	25	1441	50	2.7	72
ZPD 200 L -4	310	0.41	280	27	1455	54.5	3.2	62	30	1450	60	2.9	69
ZPD 225 M -4	440	0.7	330	37	1467	68	3.6	68	40	1465	73.5	3.3	73
ZPD 250 Mk-4	590	1.15	166	46	1470	86	3.2	170	50	1465	92	3.0	186
ZPD 250 M -4	640	1.35	200	56	1470	103	3.2	171	62	1468	112	2.9	188
ZPD 280 S-4	780	1.83	230	68	1470	130	2.8	182	75	1466	145	2.5	200
ZPD 280 M -4	870	2.23	310	94	1468	170	3.2	184	100	1466	180	3.0	196
ZPD 315 S-4	1010	3.05	275	112	1471	201	3.6	246	120	1469	215	3.5	264
ZPD 315 M -4	1115	3.72	335	137	1476	245	3.8	248	150	1474	267	3.7	271
ZPD 355 Lk-4	1515	5.72	340	160	1478	285	3.1	285	180	1476	320	2.8	320
ZPD 355 L -4	1655	7.42	440	195	1481	350	3.2	254	210	1480	375	3.0	289
ZPD 400 Lk-4	2030	11.24	610	245	1482	440	3.6	243	260	1481	460	3.4	257
ZPD 400 L-4	2320	14.06	760	300	1482	535	3.7	240	330	1480	585	3.3	264

TOTALLY ENCLOSED SLIPRING MOTORS FOR CRANES type ZPD

Mechanical protection: IP 54/55
Voltage: 380 V, 50 Hz

Type	2p=6, 1000 min ⁻¹			S3, ED 100%, 6 starts/hour					S3, ED 60%, 6 starts/hour				
	Mass kg	J kgm ²	Rotor voltage U ₂ 10% V	Output power P _N kW	Rated speed n _N min ⁻¹	Rated current I _N A	$\frac{T_m}{T}$	Rotor current I ₂ A	Output power P _N kW	Rated speed n _N min ⁻¹	Rated current I _N A	$\frac{T_m}{T}$	Rotor current I ₂ A
ZPD 160 M -6	135	0.1	170	5.5	940	13.3	3.1	19	6	935	14	3.0	21.5
ZPD 160 L -6	160	0.14	240	7.5	950	18.6	3.4	19	8.5	945	20	3.1	21.5
ZPD 180 L -6	227	0.24	233	11	958	25.5	3.0	30	13	950	29	2.5	35
ZPD 200 L -6	290	0.53	245	15	973	33	3.4	37	17.5	968	38.8	3.0	45.4
ZPD 225 Mk-6	420	0.88	250	18.5	973	38	4.0	45	22	968	45	3.4	54
ZPD 225 M -6	440	1.07	282	22	973	45	3.5	48	26	968	56	3.0	57
ZPD 250 Mk-6	570	1.52	145	30	973	61	3.0	132	34	970	68	2.8	151
ZPD 250 M -6	640	1.72	175	37	975	74	3.5	132	44	972	86	3.3	155
ZPD 280 S-6	800	2.82	150	45	975	88	4.0	182	53	971	102	3.4	214
ZPD 280 M -6	845	3.31	175	55	980	106	4.0	184	64	975	124	3.4	214
ZPD 315 S-6	1115	5.22	245	75	985	144	4.0	186	87	983	164	3.4	216
ZPD 315 M -6	1180	6.2	280	90	988	173	4.0	195	105	986	196	3.4	227
ZPD 355 Lk-6	1595	8.82	400	110	985	202	4.8	164	130	983	240	4.0	194
ZPD 355 L -6	1790	10.38	500	132	985	239	4.0	156	160	983	283	3.3	189
ZPD 400 Lk-6	2030	14.98	500	160	989	304	4.0	192	185	987	343	3.3	222
ZPD 400 L-6	2295	17.82	634	200	990	378	4.0	192	230	988	424	3.3	221

Type	2p=6, 1000 min ⁻¹			S3, ED 40%, 6 starts/hour					S3, ED 25%, 6 starts/hour				
	Mass kg	J kgm ²	Rotor voltage U ₂ 10% V	Output power P _N kW	Rated speed n _N min ⁻¹	Rated current I _N A	$\frac{T_m}{T}$	Rotor current I ₂ A	Output power P _N kW	Rated speed n _N min ⁻¹	Rated current I _N A	$\frac{T_m}{T}$	Rotor current I ₂ A
ZPD 160 M -6	135	0.1	170	7	925	16	2.5	25.5	8	915	19	2.1	29.2
ZPD 160 L -6	160	0.14	240	10	935	22.4	2.6	25.4	11.5	925	25	2.2	29.1
ZPD 180 L -6	227	0.24	233	15	940	33	2.2	41	17.5	930	38	1.9	48
ZPD 200 L -6	290	0.53	245	20	962	43	2.6	52.6	23	955	48.8	2.2	61.5
ZPD 225 Mk-6	420	0.88	250	25	964	50	3.0	61	30	957	60	2.5	73
ZPD 225 M -6	440	1.07	282	30	963	64	2.6	65	35	957	73	2.2	76
ZPD 250 Mk-6	570	1.52	145	40	965	79	2.4	181	48	958	95	2.0	223
ZPD 250 M -6	640	1.72	175	50	970	97	2.9	183	60	962	117	2.5	225
ZPD 280 S-6	800	2.82	150	63	965	123	2.9	254	72	960	143	2.5	291
ZPD 280 M -6	845	3.31	175	75	970	142	2.9	251	85	965	165	2.5	285
ZPD 315 S-6	1115	5.22	245	100	981	186	3.0	248	115	978	217	2.6	285
ZPD 315 M -6	1180	6.2	280	120	984	224	3.0	260	140	982	260	2.6	303
ZPD 355 Lk-6	1595	8.82	400	155	980	284	3.4	231	175	975	320	3.0	261
ZPD 355 L -6	1790	10.38	500	175	982	308	3.0	207	200	980	348	2.6	236
ZPD 400 Lk-6	2030	14.98	500	220	985	400	3.0	264	240	984	433	2.6	288
ZPD 400 L-6	2295	17.82	634	270	986	485	3.0	260	300	985	534	2.7	288

TOTALLY ENCLOSED SLIPRING MOTORS FOR CRANES type ZPD

7

Mechanical protection: IP 54/55

Voltage: 380 V, 50 Hz

Type	2p=6, 1000 min ⁻¹		S4, S5 ED 25%, 150 starts/hour					S4, S5 ED 40%, 150 starts/hour					
	Mass kg	J kgm ²	Rotor voltage U ₂ 10% V	Output power P _N kW	Rated speed n _N min ⁻¹	Rated current I _N A	$\frac{T_m}{T}$	Rotor current I ₂ A	Output power P _N kW	Rated speed n _N min ⁻¹	Rated current I _N A	$\frac{T_m}{T}$	Rotor current I ₂ A
ZPD 160 M -6	135	0.1	170	7	925	16	2.5	24	6	935	14	3.0	21.8
ZPD 160 L -6	160	0.14	240	9.5	940	21.3	2.7	24	8.5	945	20	3.1	21.5
ZPD 180 L -6	227	0.24	233	14	944	31	2.4	38	12.5	950	28	2.7	34
ZPD 200 L -6	290	0.53	245	19	964	41.3	2.7	50	17	970	38	3.0	44
ZPD 225 Mk-6	420	0.88	250	23	967	47	3.2	56	21	970	44	3.5	51
ZPD 225 M -6	440	1.07	282	28	966	60	2.9	61	25	970	54	3.1	55
ZPD 250 Mk-6	570	1.52	145	38	965	75	2.7	171	33	970	66	3.0	146
ZPD 250 M -6	640	1.72	175	47	970	92	3.2	171	42	974	83	3.5	151
ZPD 280 S-6	800	2.82	150	57	970	110	3.1	230	50	974	96	3.6	202
ZPD 280 M -6	845	3.31	175	70	973	135	3.1	234	62	976	120	3.6	207
ZPD 315 S-6	1115	5.22	245	95	982	178	3.1	236	84	987	159	3.6	208
ZPD 315 M -6	1180	6.2	280	113	985	210	3.1	245	100	987	188	3.6	217
ZPD 355 Lk-6	1595	8.82	400	140	982	260	3.7	209	123	984	227	4.3	183
ZPD 355 L -6	1790	10.38	500	167	983	295	3.1	197	148	984	265	3.6	175
ZPD 400 Lk-6	2030	14.98	500	203	986	274	3.1	244	180	988	335	3.6	216
ZPD 400 L-6	2295	17.82	634	253	987	458	3.1	243	225	989	415	3.6	216

Type	2p=6, 1000 min ⁻¹		S4, S5 ED 60%, 150 starts/hour					S4, S5 ED 40%, 300 starts/hour					
	Mass kg	J kgm ²	Rotor voltage U ₂ 10% V	Output power P _N kW	Rated speed n _N min ⁻¹	Rated current I _N A	$\frac{T_m}{T}$	Rotor current I ₂ A	Output power P _N kW	Rated speed n _N min ⁻¹	Rated current I _N A	$\frac{T_m}{T}$	Rotor current I ₂ A
ZPD 160 M -6	135	0.1	170	5.5	940	13.3	3.1	19	5.5	940	13.3	3.1	19
ZPD 160 L -6	160	0.14	240	7.5	950	18.6	3.4	19	7.5	950	18.6	3.4	19
ZPD 180 L -6	227	0.24	233	11	958	25.5	3.0	30	10.5	960	25	3.2	29
ZPD 200 L -6	290	0.53	245	15	973	34.8	3.4	38.5	14	975	33.3	3.6	35.8
ZPD 225 Mk-6	420	0.88	250	18.5	973	40	4.0	45	18	974	39	4.1	44
ZPD 225 M -6	440	1.07	282	22	973	49	3.5	48	21	974	47	3.6	46
ZPD 250 Mk-6	570	1.52	145	30	973	61	3.0	132	28	975	58	3.2	123
ZPD 250 M -6	640	1.72	175	37	975	74	3.5	132	35	975	71	3.7	125
ZPD 280 S-6	800	2.82	150	45	975	88	4.0	182	43	978	84	4.2	174
ZPD 280 M -6	845	3.31	175	55	980	106	4.0	184	52	981	104	4.2	174
ZPD 315 S-6	1115	5.22	245	75	985	144	4.0	186	72	986	138	4.2	178
ZPD 315 M -6	1180	6.2	280	90	988	173	4.0	195	85	989	164	4.2	184
ZPD 355 Lk-6	1595	8.82	400	110	985	202	4.8	164	105	986	196	5.0	156
ZPD 355 L -6	1790	10.38	500	132	985	239	4.0	156	126	986	230	4.2	149
ZPD 400 Lk-6	2030	14.98	500	160	989	304	4.0	192	153	989	394	4.2	184
ZPD 400 L-6	2295	17.82	634	200	990	378	4.0	192	190	990	363	4.2	183

TOTALLY ENCLOSED SLIPRING MOTORS FOR CRANES type ZPD

Mechanical protection: IP 54/55
Voltage: 380 V, 50 Hz

Type	2p=6, 1000 min ⁻¹			S4, S5 ED 60%, 300 starts/hour				S4, S5 ED 60%, 600 starts/hour					
	Mass kg	J kgm ²	Rotor voltage U ₂ 10% V	Output power P _N kW	Rated speed n _N min ⁻¹	Rated current I _N A	$\frac{T_m}{T}$	Rotor current I ₂ A	Output power P _N kW	Rated speed n _N min ⁻¹	Rated current I _N A	$\frac{T_m}{T}$	Rotor current I ₂ A
ZPD 160 M -6	135	0.1	170	5	950	12.3	3.5	16.5	4	960	10.8	4.4	14
ZPD 160 L -6	160	0.14	240	6.5	955	17.4	4.0	16.5	5.5	965	16.4	4.8	14
ZPD 180 L -6	227	0.24	233	9.5	964	24	3.5	26	7.5	972	21	4.4	20.5
ZPD 200 L -6	290	0.53	245	13	977	31.8	3.9	33	10	982	28	5.0	25.3
ZPD 225 Mk-6	420	0.88	250	16	973	36	4.6	39	12.5	980	30	5.9	30
ZPD 225 M -6	440	1.07	282	19	977	44	4.1	42	15	980	38	5.2	33
ZPD 250 Mk-6	570	1.52	145	25	977	53	3.8	109	20	980	45	4.7	87
ZPD 250 M -6	640	1.72	175	32	980	66	4.3	113	25	984	56	5.2	88
ZPD 280 S -6	800	2.82	150	38	980	75	4.7	154	30	984	63	6.0	121
ZPD 280 M -6	845	3.31	175	47	982	95	4.7	157	37	985	82	6.0	124
ZPD 315 S -6	1115	5.22	245	64	987	124	4.7	159	50	989	105	6.0	124
ZPD 315 M -6	1180	6.2	280	77	990	152	4.7	167	60	992	128	6.0	130
ZPD 355 Lk-6	1595	8.82	400	95	987	178	5.5	142	74	990	147	7.1	110
ZPD 355 L -6	1790	10.38	500	114	987	212	4.7	135	88	990	175	6.0	104
ZPD 400 Lk-6	2030	14.98	500	138	990	272	4.7	166	107	991	229	6.0	128
ZPD 400 L -6	2295	17.82	634	173	991	340	4.7	166	134	992	287	6.0	128

Type	2p=6, 1000 min ⁻¹			S2, 60 min				S2, 30 min					
	Mass kg	J kgm ²	Rotor voltage U ₂ 10% V	Output power P _N kW	Rated speed n _N min ⁻¹	Rated current I _N A	$\frac{T_m}{T}$	Rotor current I ₂ A	Output power P _N kW	Rated speed n _N min ⁻¹	Rated current I _N A	$\frac{T_m}{T}$	Rotor current I ₂ A
ZPD 160 M -6	135	0.1	170	6.5	935	15	2.6	22.8	7	925	16	2.5	25.5
ZPD 160 L -6	160	0.14	240	9	942	21.2	2.8	22.8	10	935	22.4	2.6	25.4
ZPD 180 L -6	227	0.24	233	13	950	29	2.5	35	14.5	942	32	2.3	39.5
ZPD 200 L -6	290	0.53	245	18	966	39.6	2.9	46.8	20	962	43	2.6	52.5
ZPD 225 Mk-6	420	0.88	250	23	967	47	3.2	56	26	963	53	2.8	63
ZPD 225 M -6	440	1.07	282	27	967	58	2.9	59	30	963	64	2.6	65
ZPD 250 Mk-6	570	1.52	145	38	965	75	2.7	171	40	965	79	2.4	181
ZPD 250 M -6	640	1.72	175	47	970	92	3.2	171	50	970	97	2.9	183
ZPD 280 S -6	800	2.82	150	57	970	110	3.1	230	64	965	125	2.8	259
ZPD 280 M -6	845	3.31	175	70	973	135	3.1	234	78	970	151	2.8	261
ZPD 315 S -6	1115	5.22	245	95	982	178	3.1	236	105	980	198	2.8	261
ZPD 315 M -6	1180	6.2	280	115	985	212	3.1	249	130	983	240	2.8	281
ZPD 355 Lk-6	1595	8.82	400	132	982	254	4.0	197	150	980	276	3.5	224
ZPD 355 L -6	1790	10.38	500	160	983	283	3.3	189	180	981	318	2.9	213
ZPD 400 Lk-6	2030	14.98	500	195	987	358	3.3	234	220	985	400	3.0	264
ZPD 400 L -6	2295	17.82	634	240	988	438	3.3	231	270	986	485	3.0	259

TOTALLY ENCLOSED SLIPRING MOTORS FOR CRANES type ZPD

Mechanical protection: IP 54/55

Voltage: 380 V, 50 Hz

Type	2p=8, 750 min ⁻¹			S3, ED 100%, 6 starts/hour					S3, ED 60%, 6 starts/hour				
	Mass kg	J kgm ²	Rotor voltage U ₂ 10% V	Output power P _N kW	Rated speed n _N min ⁻¹	Rated current I _N A	T _m T	Rotor current I ₂ A	Output power P _N kW	Rated speed n _N min ⁻¹	Rated current I _N A	T _m T	Rotor current I ₂ A
ZPD 160 M -8	130	0.1	130	3.7	705	11	2.8	19.7	4.3	702	12.5	2.7	22.5
ZPD 160 L -8	150	0.15	200	5.5	714	16.4	3.1	19.7	6	711	17.2	2.8	20.9
ZPD 180 L -8	227	0.25	224	7.5	714	20	2.9	20	8.5	710	22	2.6	23
ZPD 200 L -8	318	0.65	260	11	720	26	3.1	28	13	713	30.3	2.7	33.8
ZPD 225 Mk-8	420	0.82	220	15	728	32	3.2	42	17.5	724	36	2.8	49
ZPD 225 M -8	455	1.0	270	18.5	728	40	3.6	42	22	723	45	3.0	49
ZPD 250 Mk-8	570	1.63	130	22	730	48	3.6	105	26	723	56	3.0	124
ZPD 250 M -8	640	1.95	170	30	730	65	3.6	105	34	725	73	3.0	120
ZPD 280 S-8	800	2.97	182	37	730	80	3.3	123	44	728	93	2.8	146
ZPD 280 M -8	865	3.5	225	45	736	94	3.6	122	53	730	116	3.0	144
ZPD 315 S-8	1080	6.4	280	55	737	107	3.8	120	64	735	121	3.2	140
ZPD 315 M -8	1230	7.9	380	75	740	151	3.4	120	87	738	170	2.9	139
ZPD 355 Lk-8	1595	10.87	335	90	738	185	4.3	163	105	737	207	3.7	191
ZPD 355 L -8	1790	12.12	435	110	740	225	4.3	153	130	739	256	3.7	182
ZPD 400 Lk-8	2135	23.7	460	132	742	251	3.2	174	160	740	302	2.7	211
ZPD 400 L-8	2400	28.42	560	160	742	305	3.2	174	185	740	350	2.7	201

Type	2p=8, 750 min ⁻¹			S3, ED 40%, 6 starts/hour					S3, ED 25%, 6 starts/hour				
	Mass kg	J kgm ²	Rotor voltage U ₂ 10% V	Output power P _N kW	Rated speed n _N min ⁻¹	Rated current I _N A	T _m T	Rotor current I ₂ A	Output power P _N kW	Rated speed n _N min ⁻¹	Rated current I _N A	T _m T	Rotor current I ₂ A
ZPD 160 M -8	130	0.1	130	5	692	13.7	2.3	26.8	5.6	674	14.9	1.8	32.9
ZPD 160 L -8	150	0.15	120	7	703	18.8	2.4	24.8	8	694	20.7	2.1	29
ZPD 180 L -8	227	0.25	224	10	700	25	2.2	27	11.5	690	28	1.9	31
ZPD 200 L -8	318	0.65	260	15	705	34	2.3	40	17.5	696	39.3	2.0	48
ZPD 225 Mk-8	420	0.82	220	20	720	40	2.4	56	23	715	46	2.1	65
ZPD 225 M -8	455	1.0	270	25	720	51	2.6	56	30	712	61	2.2	65
ZPD 250 Mk-8	570	1.63	130	30	720	64	2.7	143	35	713	73	2.2	167
ZPD 250 M -8	640	1.95	170	40	722	85	2.6	140	48	715	103	2.2	168
ZPD 280 S-8	800	2.97	182	50	725	104	2.4	166	60	720	123	2.0	200
ZPD 280 M -8	865	3.5	225	63	725	128	2.6	170	72	720	150	2.2	195
ZPD 315 S-8	1080	6.4	280	75	733	141	2.8	163	85	730	162	2.4	185
ZPD 315 M -8	1230	7.9	380	100	736	192	2.5	160	115	734	220	2.2	184
ZPD 355 Lk-8	1595	10.87	335	120	735	230	3.3	222	140	733	266	2.9	261
ZPD 355 L -8	1790	12.12	435	155	737	296	3.3	218	175	735	330	2.9	247
ZPD 400 Lk-8	2135	23.7	460	175	739	325	2.5	231	200	738	370	2.3	264
ZPD 400 L-8	2400	28.42	560	200	739	377	2.5	217	240	738	450	2.3	262

Type	2p=8, 750 min ⁻¹			S4, S5, ED 25%, 150 starts/hour					S4, S5, ED 40%, 150 starts/hour				
	Mass kg	J kgm ²	Rotor voltage U ₂ 10% V	Output power P _N kW	Rated speed n _N min ⁻¹	Rated current I _N A	T _m T	Rotor current I ₂ A	Output power P _N kW	Rated speed n _N min ⁻¹	Rated current I _N A	T _m T	Rotor current I ₂ A
ZPD 160 M -8	130	0.1	130	4.7	690	12.9	2.2	26.4	4.3	697	12.1	2.4	23.7
ZPD 160 L -8	150	0.15	200	7	703	18.8	2.4	24.8	6.2	709	17.5	2.7	21.6
ZPD 180 L -8	227	0.25	224	9.5	702	23	2.3	25	8.5	710	22	2.6	23
ZPD 200 L -8	318	0.65	260	14	709	32.2	2.5	36.8	12	716	28.6	2.8	31
ZPD 225 Mk-8	420	0.82	220	18.5	723	38	2.6	52	16.5	726	34	2.9	46
ZPD 225 M -8	455	1.0	270	23	722	48	2.8	51	20	726	42	3.2	45
ZPD 250 Mk-8	570	1.63	130	28	721	60	2.8	134	24	725	53	3.3	115
ZPD 250 M -8	640	1.95	170	38	722	80	2.8	133	33	727	71	3.2	115
ZPD 280 S-8	800	2.97	182	47	727	97	2.6	156	41	730	88	3.0	136
ZPD 280 M -8	865	3.5	225	57	727	123	2.8	155	50	731	112	3.2	136
ZPD 315 S-8	1080	6.4	280	69	734	130	3.0	150	60	736	115	3.4	131
ZPD 315 M -8	1230	7.9	380	95	736	184	2.7	152	83	738	163	3.1	133
ZPD 355 Lk-8	1595	10.87	335	114	736	222	3.5	210	100	737	200	4.0	183
ZPD 355 L -8	1790	12.12	435	138	738	270	3.5	193	121	740	245	4.0	167
ZPD 400 Lk-8	2135	23.7	460	165	740	310	2.7	218	145	741	275	3.0	191
ZPD 400 L-8	2400	28.42	560	200	740	377	2.7	217	176	741	335	3.0	191

TOTALLY ENCLOSED SLIPRING MOTORS FOR CRANES type ZPD

Mechanical protection: IP 54/55
Voltage: 380 V, 50 Hz

2p=8, 750 min ⁻¹				S4, S5, ED 60%, 150 starts/hour					S4, S5, ED 40%, 300 starts/hour				
Type	Mass kg	J kgm ²	Rotor voltage U ₂ 10% V	Output power P _N kW	Rated speed n _N min ⁻¹	Rated current I _N A	T _m T	Rotor current I ₂ A	Output power P _N kW	Rated speed n _N min ⁻¹	Rated current I _N A	T _m T	Rotor current I ₂ A
ZPD 160 M -8	130	0.1	130	3.7	705	11	2.8	19.7	3.6	707	11	2.8	19.5
ZPD 160 L -8	150	0.15	200	5.5	714	16.4	3.1	18.7	5.5	714	16.4	3.1	18.7
ZPD 180 L -8	227	0.25	224	7.5	714	20	2.9	20	7	716	19	3.1	19
ZPD 200 L -8	318	0.65	260	11	720	27	3.1	28	10.5	721	26.2	3.4	26.8
ZPD 225 Mk-8	420	0.82	220	15	728	32	3.2	42	14.5	729	31	3.4	41
ZPD 225 M -8	455	1.0	270	18.5	728	40	3.6	41	17.5	729	38	3.7	39
ZPD 250 Mk-8	570	1.63	130	22	730	50	3.6	105	21	728	48	3.8	100
ZPD 250 M -8	640	1.95	170	30	730	66	3.5	105	28	730	63	3.8	98
ZPD 280 S -8	800	2.97	182	37	730	80	3.3	123	35	732	79	3.5	116
ZPD 280 M -8	865	3.5	225	45	735	100	3.5	122	43	732	102	3.7	117
ZPD 315 S -8	1080	6.4	280	55	737	107	3.8	120	53	738	103	3.9	116
ZPD 315 M -8	1230	7.9	380	75	740	151	3.4	120	72	741	146	3.6	115
ZPD 355 Lk-8	1595	10.87	335	90	738	182	4.3	163	85	740	178	4.5	155
ZPD 355 L -8	1790	12.12	435	110	740	227	4.3	153	105	741	222	4.6	146
ZPD 400 Lk-8	2135	23.7	460	132	742	251	3.2	174	126	742	245	3.5	166
ZPD 400 L -8	2400	28.42	560	160	742	305	3.2	174	153	742	298	3.5	166

2p=8, 750 min ⁻¹				S4, S5, ED 60%, 300 starts/hour					S4, S5, ED 60%, 600 starts/hour				
ZPD 160 M -8	130	0.1	130	3.2	712	10.4	3.2	17.1	2.6	720	9.6	4.0	13.7
ZPD 160 L -8	150	0.15	200	5.2	717	16	3.3	17.9	3.7	727	14.2	4.6	12.6
ZPD 180 L -8	227	0.25	224	6.5	720	18	3.4	17	5	725	16	4.4	13
ZPD 200 L -8	318	0.65	260	9.5	724	24.7	3.6	24	7.5	730	22	4.6	18.8
ZPD 225 Mk-8	420	0.82	220	13	730	29	3.7	36	10	735	25	4.8	28
ZPD 225 M -8	455	1.0	270	16	730	35	4.1	36	12.5	736	30	5.3	28
ZPD 250 Mk-8	570	1.63	130	19	730	45	4.2	91	15	735	40	5.4	72
ZPD 250 M -8	640	1.95	170	26	732	60	4.1	91	20	735	52	5.3	70
ZPD 280 S -8	800	2.97	182	32	734	75	3.9	106	25	737	65	5.0	83
ZPD 280 M -8	865	3.5	225	39	734	96	4.1	106	30	738	86	5.2	82
ZPD 315 S -8	1080	6.4	280	48	738	96	4.3	105	37	741	80	5.6	81
ZPD 315 M -8	1230	7.9	380	65	742	135	4.0	104	50	743	115	5.1	80
ZPD 355 Lk-8	1595	10.87	335	78	741	167	5.0	142	62	742	145	6.0	113
ZPD 355 L -8	1790	12.12	435	96	742	210	5.0	133	73	744	180	6.2	101
ZPD 400 Lk-8	2135	23.7	460	115	743	228	3.8	152	88	745	188	4.9	116
ZPD 400 L -8	2400	28.42	560	139	743	275	3.8	151	106	745	226	4.9	115

2p=8, 750 min ⁻¹				S2, 60 min					S2, 30 min				
ZPD 160 M -8	130	0.1	130	4.4	695	12.3	2.3	24.4	4.8	689	13.1	2.1	27
ZPD 160 L -8	150	0.15	200	6.5	707	18	2.6	22.8	7.2	701	19.2	2.3	25.6
ZPD 180 L -8	227	0.25	224	9	705	22	2.4	24	10	700	25	2.2	27
ZPD 200 L -8	318	0.65	260	13.5	711	31.2	2.6	35.3	15	705	34	2.3	40
ZPD 225 Mk-8	420	0.82	220	18.5	723	38	2.6	52	21	719	42	2.3	59
ZPD 225 M -8	455	1.0	270	23	722	48	2.8	51	26	718	53	2.5	58
ZPD 250 Mk-8	570	1.63	130	27	722	58	2.9	129	30	720	64	2.7	143
ZPD 250 M -8	640	1.95	170	37	725	78	2.8	129	40	722	85	2.6	140
ZPD 280 S -8	800	2.97	182	46	728	96	2.6	153	52	724	108	2.4	173
ZPD 280 M -8	865	3.5	225	56	728	121	2.8	152	64	724	135	2.6	173
ZPD 315 S -8	1080	6.4	280	69	734	130	3.0	150	78	732	147	2.7	170
ZPD 315 M -8	1230	7.9	380	95	736	184	2.6	152	105	735	200	2.4	168
ZPD 355 Lk-8	1595	10.87	335	112	736	218	3.5	206	127	734	243	3.1	235
ZPD 355 L -8	1790	12.12	435	137	739	270	3.7	192	155	737	297	3.3	218
ZPD 400 Lk-8	2135	23.7	460	160	740	302	2.7	211	185	738	344	2.5	244
ZPD 400 L -8	2400	28.42	560	200	740	377	2.7	217	225	739	422	2.5	245

TOTALLY ENCLOSED SLIPRING MOTORS FOR CRANES type ZPD

Mechanical protection: IP 54/55

Voltage: 380 V, 50 Hz

Type	2p=10, 600 min ⁻¹			S3, ED 100%, 6 starts/hour					S3, ED 60%, 6 starts/hour				
	Mass kg	J kgm ²	Rotor voltage U ₂ 10% V	Output power P _N kW	Rated speed n _N min ⁻¹	Rated current I _N A	$\frac{T_m}{T}$	Rotor current I ₂ A	Output power P _N kW	Rated speed n _N min ⁻¹	Rated current I _N A	$\frac{T_m}{T}$	Rotor current I ₂ A
ZPD 250 Mk-10	600	1.7	120	18.5	578	47	3.2	100	22	574	53	2.7	119
ZPD 250 M-10	650	2.0	160	22	582	61	3.0	90	26	579	65	2.5	107
ZPD 280 S-10	800	2.6	155	30	585	77	3.1	120	34	583	83	2.6	136
ZPD 280 M-10	880	3.3	195	37	585	94	3.2	120	44	583	105	2.7	142
ZPD 315 S-10	1145	5.4	250	45	588	110	3.7	110	53	586	122	3.1	123
ZPD 315 M-10	1260	6.6	310	55	590	134	3.9	110	64	589	146	3.4	128
ZPD 355 Lk-10	1645	12.3	285	75	588	154	3.7	160	87	587	175	3.2	187
ZPD 355 L-10	1830	15.3	355	90	590	185	4.0	154	105	588	210	3.5	179
ZPD 400 Lk-10	2215	20	390	110	594	245	3.0	172	130	593	275	2.5	204
ZPD 400 L-10	2480	23.7	460	132	594	280	3.0	173	160	593	325	2.5	210

Type	2p=10, 600 min ⁻¹			S3, ED 40%, 6 starts/hour					S3, ED 25%, 6 starts/hour				
	Mass kg	J kgm ²	Rotor voltage U ₂ 10% V	Output power P _N kW	Rated speed n _N min ⁻¹	Rated current I _N A	$\frac{T_m}{T}$	Rotor current I ₂ A	Output power P _N kW	Rated speed n _N min ⁻¹	Rated current I _N A	$\frac{T_m}{T}$	Rotor current I ₂ A
ZPD 250 Mk-10	600	1.7	120	25	570	58	2.4	135	30	565	66	2.0	162
ZPD 250 M-10	650	2.0	160	30	576	73	2.2	123	35	572	82	1.9	143
ZPD 280 S-10	800	2.6	155	40	580	94	2.3	160	48	575	112	2.0	192
ZPD 280 M-10	880	3.3	195	50	580	116	2.4	162	60	577	137	2.1	194
ZPD 315 S-10	1145	5.4	250	63	583	140	2.6	154	72	580	154	2.3	196
ZPD 315 M-10	1260	6.6	310	75	587	166	2.9	153	85	586	186	2.6	170
ZPD 355 Lk-10	1645	12.3	285	100	585	198	2.8	217	115	583	223	2.5	252
ZPD 355 L-10	1830	15.3	355	120	586	235	3.1	206	140	584	268	2.7	243
ZPD 400 Lk-10	2215	20	390	155	592	315	2.2	244	175	591	350	2.0	278
ZPD 400 L-10	2480	23.7	460	175	592	350	2.2	231	200	591	392	2.0	267

Type	2p=10, 600 min ⁻¹			S4, S5, ED 25%, 150 starts/hour					S4, S5, ED 40%, 150 starts/hour				
	Mass kg	J kgm ²	Rotor voltage U ₂ 10% V	Output power P _N kW	Rated speed n _N min ⁻¹	Rated current I _N A	$\frac{T_m}{T}$	Rotor current I ₂ A	Output power P _N kW	Rated speed n _N min ⁻¹	Rated current I _N A	$\frac{T_m}{T}$	Rotor current I ₂ A
ZPD 250 Mk-10	600	1.7	120	24	571	56	2.5	130	21	575	52	2.8	113
ZPD 250 M-10	650	2.0	160	28	578	70	2.4	115	24	581	64	2.7	98
ZPD 280 S-10	800	2.6	155	38	581	92	2.4	152	33	584	82	2.8	132
ZPD 280 M-10	880	3.3	195	47	583	110	2.5	152	42	585	101	2.9	136
ZPD 315 S-10	1145	5.4	250	57	585	129	2.9	140	51	587	120	2.3	125
ZPD 315 M-10	1260	6.6	310	70	588	156	3.1	140	62	589	144	3.5	124
ZPD 355 Lk-10	1645	12.3	285	96	586	190	2.9	207	85	587	173	3.3	183
ZPD 355 L-10	1830	15.3	355	115	587	225	3.2	197	103	588	206	3.6	176
ZPD 400 Lk-10	2215	20	390	140	593	290	2.3	220	124	594	265	2.6	194
ZPD 400 L-10	2480	23.7	460	168	593	338	2.3	222	150	594	308	2.6	197

Type	2p=10, 600 min ⁻¹			S4, S5, ED 60%, 150 starts/hour					S4, S5, ED 40%, 300 starts/hour				
	Mass kg	J kgm ²	Rotor voltage U ₂ 10% V	Output power P _N kW	Rated speed n _N min ⁻¹	Rated current I _N A	$\frac{T_m}{T}$	Rotor current I ₂ A	Output power P _N kW	Rated speed n _N min ⁻¹	Rated current I _N A	$\frac{T_m}{T}$	Rotor current I ₂ A
ZPD 250 Mk-10	600	1.7	120	18.5	578	47	3.2	100	18	578	46	3.3	98
ZPD 250 M-10	650	2.0	160	22	582	61	3.0	90	21	583	60	3.2	86
ZPD 280 S-10	800	2.6	155	30	585	77	3.1	120	29	586	75	3.3	116
ZPD 280 M-10	880	3.3	195	37	585	94	3.2	120	36	587	92	3.4	117
ZPD 315 S-10	1145	5.4	250	45	588	110	3.7	110	43	589	107	3.8	105
ZPD 315 M-10	1260	6.6	310	55	590	134	3.9	110	53	591	131	4.1	106
ZPD 355 Lk-10	1645	12.3	285	75	588	154	3.7	160	72	589	153	3.8	154
ZPD 355 L-10	1830	15.3	355	90	590	185	4.0	154	86	590	180	4.1	146
ZPD 400 Lk-10	2215	20	390	110	594	245	3.0	172	105	594	238	3.1	164
ZPD 400 L-10	2480	23.7	460	132	594	280	3.0	173	128	594	275	3.1	167

TOTALLY ENCLOSED SLIPRING MOTORS FOR CRANES type ZPD

Mechanical protection: IP 54/55
Voltage: 380 V, 50 Hz

Type	Mass kg	J kgm ²	Rotor voltage U ₂ 10% V	S4, S5, ED 60%, 300 starts/hour					S4, S5, ED 60%, 600 starts/hour				
				Output power P _N kW	Rated speed n _N min ⁻¹	Rated current I _N A	T _m T	Rotor current I ₂ A	Output power P _N kW	Rated speed n _N min ⁻¹	Rated current I _N A	T _m T	Rotor current I ₂ A
2p=10, 600 min ⁻¹													
ZPD 250 Mk-10	600	1.7	120	16	581	43	3.7	86	12	585	37	5.0	65
ZPD 250 M-10	650	2.0	160	19	585	57	3.5	78	14	589	51	4.8	58
ZPD 280 S-10	800	2.6	155	26	587	71	3.6	109	20	590	62	4.9	80
ZPD 280 M-10	880	3.3	195	32	588	86	3.7	104	24	591	75	5.0	78
ZPD 315 S-10	1145	5.4	250	38	590	100	4.4	93	30	592	90	5.5	73
ZPD 315 M-10	1260	6.6	310	46	592	122	4.7	92	36	594	110	6.1	72
ZPD 355 Lk-10	1645	12.3	285	64	591	140	4.3	136	50	593	122	5.5	106
ZPD 355 L-10	1830	15.3	355	76	592	166	4.7	129	59	594	145	6.0	100
ZPD 400 Lk-10	2215	20	390	93	595	220	3.7	144	72	596	195	4.7	112
ZPD 400 L-10	2480	23.7	460	110	595	250	3.7	143	86	596	217	4.7	112

Type	Mass kg	J kgm ²	Rotor voltage U ₂ 10% V	S2, 60 min				S2, 30 min					
				Output power P _N kW	Rated speed n _N min ⁻¹	Rated current I _N A	T _m T	Output power P _N kW	Rated speed n _N min ⁻¹	Rated current I _N A	T _m T		
2p=10, 600 min ⁻¹													
ZPD 250 Mk-10	600	1.7	120	24	571	56	2.4	130	26	569	60	2.2	140
ZPD 250 M-10	650	2.0	160	28	578	70	2.2	115	31	575	75	2.0	127
ZPD 280 S-10	800	2.6	155	38	581	92	2.4	152	42	579	100	2.1	168
ZPD 280 M-10	880	3.3	195	47	583	110	2.5	152	53	580	122	2.2	172
ZPD 315 S-10	1145	5.4	250	57	585	129	2.9	139	65	582	142	2.5	159
ZPD 315 M-10	1260	6.6	310	70	588	156	3.1	140	80	587	175	2.7	160
ZPD 355 Lk-10	1645	12.3	285	96	586	190	2.9	207	109	584	213	2.6	238
ZPD 355 L-10	1830	15.3	355	115	587	225	3.2	197	132	585	255	2.8	228
ZPD 400 Lk-10	2215	20	390	140	592	292	2.3	221	163	591	330	2.1	258
ZPD 400 L-10	2480	23.7	460	168	592	338	2.3	222	195	591	382	2.1	259

Designation	Dimension	Tolerances
D, DA	50 mm > 50 mm	k 6 m 6
N		j 6
A and B	500 mm > 500 mm	1.00 mm 1.50 mm
M	> 200 500 mm > 500 mm	0.50 mm 1.00 mm
H	250 mm > 250 mm	0.50 mm 1.00 mm
F and FA	Width of key Width of slot	h 9 P 9
K		H 14

Type	Cable inlets	Max diameter of cables, mm		Terminals	
		Stator	Rotor	Stator	Rotor
160	2xAU29x27	30	30	M 6	M 6
180 200	2xAU36x27	38	38	M 8	M 8
225 250 280	2x54	54	54	M 10	M 10
315 355	2x64	64	64	M 12	M 12
400	2x75	75	75	M 16	M 16

Table 1
DATA FOR TERMINAL BOX

Motor type		Horizontal shaft		Vertical shaft	
Size	Number of Poles	Drive end	Drive end	Drive end	Drive end
160 M, L	4, 6	62102RS C3	62102RS C3	62102RS C3	62102RS C3
180 L	4, 6, 8	6311 C3	6311 C3	6311 C3	6311 C3
200 L	4, 6, 8	6312 C3	6312 C3	6312 C3	6312 C3
225 M	4, 6, 8	6313 C3	6313 C3	6313 C3	6313 C3
250 M	4, 6, 8, 10	NU314	6314 C3	NU314	6314 C3
280 M, S	4, 6, 8, 10	NU316	6316 C3	NU316	6316 C3
315 M, S	4, 6, 8, 10	NU319	6317 C3	NU319	7317 B
355 L	4, 6, 8, 10	NU322	6319 C3	NU322	7319 B
400 L	4, 6, 8, 10	NU324	6320 C3	NU324	7320 B

Table 2
BEARINGS

SHAPE: B3

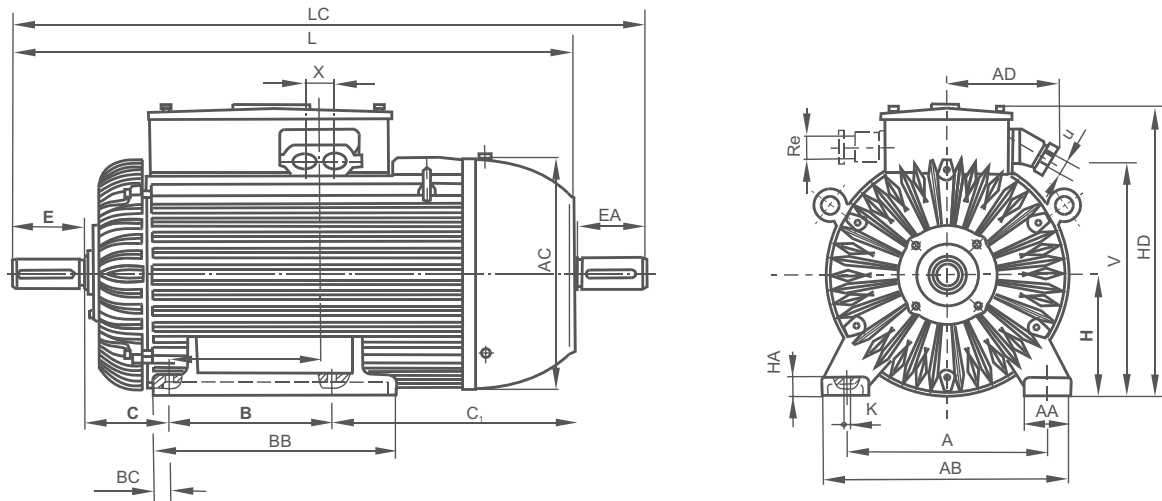

SHAPE: B3, V1

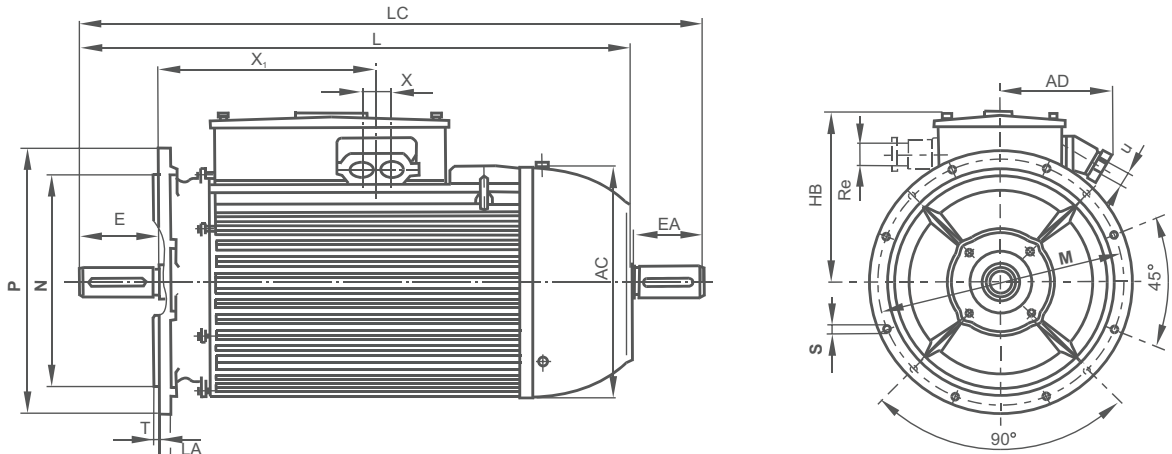

ZPD 355
ZPD 400 only for shape V1

SHAFT - ENDS

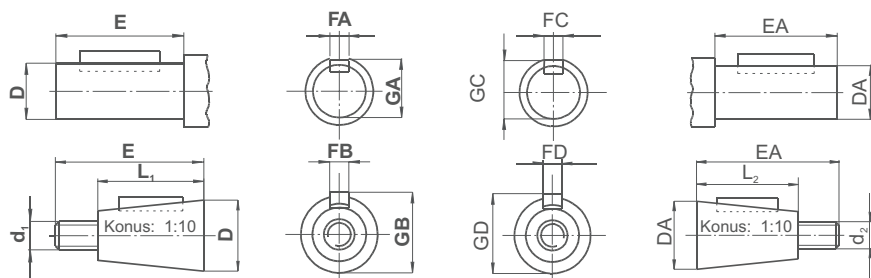

On special request motors are produced with conical shaft-end with internal thread.

TOTALLY ENCLOSED SLIPRING MOTORS FOR CRANES type ZPD

Type	A	AA	AB	AC	AD	B	BB	BC	C	C ₁	H	HA	HD	K	L	LC	Re	u	V	X	X ₁
ZPD 160 M	254	60	314	318	155	210	320	25	108	335	160	25	385	15	756	873	Re29	-	320	80	185
ZPD 160 L	254	60	314	318	155	254	365	25	108	335	160	25	385	15	800	917	Re29	-	320	80	185
ZPD 180 L	279	70	349	352	200	279	400	27.5	121	360	180	30	455	15	865	980	Re36	-	350	110	245
ZPD 200 Lk, L	318	80	398	395	200	305	458	34.5	133	400	200	35	495	19	943	1058	Re36	-	390	110	280
ZPD 225 Mk, M	356	90	446	444	275	311	453	34.5	149	461	225	40	575	19	1056	1171	-	54	432	110	390
ZPD 250 Mk, M	406	100	506	490	275	349	517	40.5	168	540	250	40	620	24	1194	1337	-	54	475	110	390
ZPD 280 S	457	110	567	537	275	368	525	34.5	190	540	280	45	680	24	1265	1408	-	54	535	110	410
ZPD 280 M	457	110	567	537	275	419	575	34.5	190	540	280	45	680	24	1316	1459	-	54	535	110	410
ZPD 315 S	508	125	633	598	310	406	606	42.5	216	600	315	50	745	28	1387	1532	-	64	510	128	425
ZPD 315 M	508	125	633	598	310	457	657	42.5	216	600	315	50	745	28	1438	1583	-	64	510	128	425
ZPD 355 Lk, L	610	140	750	688	310	630	895	60	254	616	355	50	830	28	1707	1882	-	64	660	128	430
ZPD 400 Lk, L	686	195	840	782	360	710	1050	60	280	630	400	62	950	35	1825	2000	-	75	750	150	500

Type	AC	AD	HB	L	LA	LC	M	N	P	S	Holes	T	Re	u	X	X ₁
ZPDF 160 M	318	155	225	756	20	873	300	250	350	19	4	5	Re29	-	80	295
ZPDF 160 L	318	155	225	800	20	917	300	250	350	19	4	5	Re29	-	80	295
ZPDF 180 L	352	200	275	865	20	980	300	250	350	19	4	5	Re36	-	110	365
ZPDF 200 Lk, L	395	200	295	943	20	1058	350	300	400	19	4	5	Re36	-	110	415
ZPDF 225 Mk, M	444	275	350	1056	20	1171	400	350	450	19	8	5	-	54	110	540
ZPDF 250 Mk, M	490	275	370	1194	22	1337	500	450	550	19	8	5	-	54	110	560
ZPDF 280 S	537	275	400	1265	22	1408	500	450	550	19	8	5	-	54	110	600
ZPDF 280 M	537	275	400	1316	22	1459	500	450	550	19	8	5	-	54	110	600
ZPDF 315 S	598	310	430	1387	25	1532	600	550	660	24	8	6	-	64	128	640
ZPDF 315 M	598	310	430	1438	25	1583	600	550	660	24	8	6	-	64	128	640
ZPDF 355 Lk, L	688	310	475	1707	25	1882	740	680	800	24	8	6	-	64	128	685
ZPDF 400 Lk, L	782	360	550	1825	25	2000	740	680	800	24	8	6	-	75	150	780

Type	E	EA	D	DA	FA	FC	GA	GC	L1	L2	FB	FD	GB	GD	d1	d2
ZPD(F) 160	110	110	42	42	12	12	45	45	82	82	10	10	42.9	42.9	M 24 X 2	M 24 X 2
ZPD(F) 180	110	110	48	48	14	14	51.5	51.5	82	82	12	12	48.9	48.9	M 30 X 2	M 30 X 2
ZPD(F) 200	110	110	55	55	16	16	59	59	82	82	14	14	56.4	56.4	M 36 X 3	M 36 X 3
ZPD(F) 225	140	110	60	55	18	16	64	59	105	82	16	14	61.4	56.4	M 42 X 3	M 36 X 3
ZPD(F) 250	140	140	70	60	20	18	74.5	64	105	105	18	16	71.4	61.4	M 48 X 3	M 42 X 3
ZPD(F) 280	170	140	80	65	22	18	85	69	130	105	20	16	81.2	66.4	M 56 X 4	M 42 X 3
ZPD(F) 315	170	140	90	70	25	20	95	74.5	130	105	22	18	91.7	71.4	M 64 X 4	M 48 X 3
ZPD(F) 355	210	170	100	80	28	22	106	85	165	130	25	20	100.9	81.2	M 72 X 4	M 56 X 4
ZPD(F) 400	210	170	110	90	28	25	116	95	165	130	25	22	110.9	91.7	M 80 X 4	M 64 X 4

TOTALLY ENCLOSED SLIPRING MOTORS FOR CRANES type ZPD

QUESTIONNAIRE FOR THE OFFER OF ASYNCHRONOUS ELECTRIC MOTORS

15



Enquiry Number: _____

Customer: _____ ITEM: _____
Qty: _____

A MOTOR DATA

1 Motor type: Three phase: _____ Single phase: _____

2 Rotor type: Squirrel cage: _____ Slip-ring: _____

3 Rated output: $P_N =$ _____ kW

4 Rated voltage: $U_N =$ _____ V Connect: Star _____ Delta _____

5 Rated frequency: $f_N =$ _____ Hz

6 Rated speed: $n_N =$ _____ rpm

7 Insulation class: F B

8 Duty type: S1 S2 S3 S4 S5 S6 S7 S8 S9 S10
ED %
starts /h _____ min _____ J_{mot} _____ kgm^2

9 Standard: _____ IEC or _____

10 Cooling method: _____ IC

11 Mounting arrangement: IM

12 Protection degree: Motor IP: _____ Terminal box IP: _____

13 *Sense of rotation: Left _____ Right _____ Both _____

14 Motor brake: yes no
Braking moment: _____ Nm
Brake voltage: _____ V/Hz _____ V,DC

15 No-load regime? (single phase motor) yes _____ no _____

16 Rotor data: $U_{2c} =$ _____ V $I_{2n} =$ _____ A

B DATA ABOUT THE DRIVEN MACHINE

1 Type: _____

2 Required power: _____

3 Required speed: _____

4 Load torque characteristic:
Constant: _____ Squared _____ or _____
Speed %: 0 25 50 75 100
Torque Nm:

5 Moment of inertia: $J =$ _____ kgm^2

6 Running machine special data: _____

C AMBIENT CONDITIONS

1 Ambient temperature: _____ C

2 Relative humidity: _____ %

3 Altitude (above sea level): _____ m

4 Specific ambient conditions: _____

D POWER TRANSMISSION AND STARTING CONDITIONS

1 Coupling type: _____

2 Starting: _____

3 Number of consecutive startings:
Hot state: _____ Cold state: _____
_____ per hour _____ per hour
_____ per day _____ per day

E ADDITIONAL REQUESTS FOR MOTOR EXECUTION

1 Overloading from: _____ % P_N
Duration: _____ min

2 Temperature rise: F B

3 Request for: vibration level _____ mm/s
noise level _____ db

4 *Terminal box position:
left right On top

5 Additional shaft loading sense
axial force _____ radial force _____

6 Converter feed operation: yes no
Converter type: _____
Manufacturer: _____
Speed range: from _____ to _____ rpm

7 Sensor category (mark in lower field):
Taho gen. _____ Encoder _____ Absolute _____ Resolver _____
Sensor Type: _____

8 Flange size: _____ mm

9 Second shaft end: yes no
DA= _____ mm EA= _____ mm

10 Other requests and limits: _____

F ADDITIONAL EQUIPMENT, SPARE PARTS AND DOCUMENTATION

1 Thermal protection: yes no
Type: _____

2 Bearings thermometers yes no

3 Anti-condensation heaters yes no

4 Spare parts yes no

5 Guarantee sheet yes no

6 Language of instruction list: _____

7 Other requests for packing: _____

You are kindly requested to provide us with as much data as possible thus enabling us to offer satisfactorily

H CUSTOMER

1 Company: _____

2 Address: _____

3 City: _____

4 Country: _____

5 Person: _____

6 Telefon / Telefax: _____

7 e-mail: _____

ATB Group - a global player

a company of **A-TEC INDUSTRIES AG**



Company locations

HEAD OFFICE AUSTRIA

ATB Austria Antriebstechnik AG

Renngasse 6-8
1010 Wien, Austria

T: +43 1 90 250 - 0
F: +43 1 90 250 110

info@atb-motors.com
www.atb-motors.com

AUSTRIA

ATB Motorenwerke GmbH

G.-Bauknecht-Str. 1
8724 Spielberg
T: +43 3577 757-323
F: +43 3577 757-182
info@atb-motors.com

ATB Technologies GmbH

Millenium Park 11
6890 Lustenau
T: +43 5577 9010-0
F: +43 5577 9010-110
info@atb-motors.com

ASIA

ATB Motorentechnik GmbH

141 Market Street,
07-01 International Factors
Building
Singapore 048944
T: +65 63721174
F: +65 62253524
dennis.tan@atbs.com.sg

BAHREIN

ATB Austria Antriebstechnik Aktiengesellschaft, Rep. Office Bahrain

Almoayyed Tower
21st Floor c/o Regus
Seef District, Manama
Kingdom of Bahrain
T: +973 175 68 160
F: +973 175 67 901

BENELUX

ATB BeNeLux B.V.

Tasveld 14
8271 RW IJsselmuiden
T: +31 38 443 2110
F: +31 38 443 2111
verkoop@nl.atb-motors.com

GERMANY

ATB Antriebstechnik GmbH

Silcherstraße 74
73642 Welzheim
T: +49 7182 14-535
F: +49 7182 14 590
info@de.atb-motors.com

ATB Motorentechnik GmbH

Helgoländer Damm 75
26954 Nordenham
T: +49 4731 365-0
F: +49 4731 365-159
info@de.atb-motors.com

Schorch Elektrische Maschinen und Antriebe GmbH

Breite Straße 131
41238 Mönchengladbach
T: +49 2166 925-0
T: +49 2166 925-100
mail@schorch.de

POLAND

Fabryka Silników Elektrycznych Tamel S.A.

ul. Elektryczna 6
33 100 Tarnow
T: +48 14 632 11 00
F: +48 14 632 11 02
officetamel@tamel.pl

RUSSIA

ATB Rus 000

Petrovka ul. 27
107031 Moscow
T: +7 495 95 66 326
vyacheslav.mikheyev@tecindustries.com

SERBIA

ATB SEVER D00 SUBOTICA

Magnetna polja 6
24000 Subotica
T: +381 24 665 100
F: +381 24 546 893
sever@rs.atb-motors.com

ATB FOD d.o.o.

Dorda Vajferta 16
19210 Bor
T: +381 30 423 147
fod@fod.co.rs

SWITZERLAND

ATB Schweiz AG

Industriestraße 28
5600 Lenzburg
T: +41 62 885 70-10
info@ch.atb-motors.com

UK & IRELAND

ATB Laurence Scott Ltd.

PO Box 25 Hardy Road, Norwich NR1 1JD
Norfolk
T: +44 1603 628 333
hvm.sales@laurence-scott.com

ATB Morley Limited

Bradford Road
Leeds LS28 6QA
West Yorkshire
T: +44 113 257 1734
sales@uk.atb-motors.com

Brook Crompton UK

St. Thomas Road, Huddersfield HD1 3LJ
West Yorkshire
T: +44 1484557200
F: +44 1484557201
csc@brookcrompton.com

CANADA

Brook Crompton

North America
264 Attwell Drive
M9W 5B2 Toronto, Ontario
T: +1 416 675-3844
ramzi.mallouk@brookcrompton.com

ATB SEVER DOO SUBOTICA

Magnetna polja 6

24 000 Subotica

Serbia

Tel. +381 24 665-124

Fax +381 24 665-125

www.atb-motors.com

sever@rs.atb-motors.com